

Radial Lead Type Monolithic Ceramic Capacitors



RDE Series (For General Use Only) (DC25V-DC1kV)

■ Features

1. Small size and large capacitance
2. Low ESR characteristics for high frequency
3. Meet LF (Lead Free) and HF (Halogen Free)
4. Flow soldering is available, but re-flow soldering is not available.

■ Applications

General electronic equipment
 (Do not use for automotive-related power train and safety equipment.)

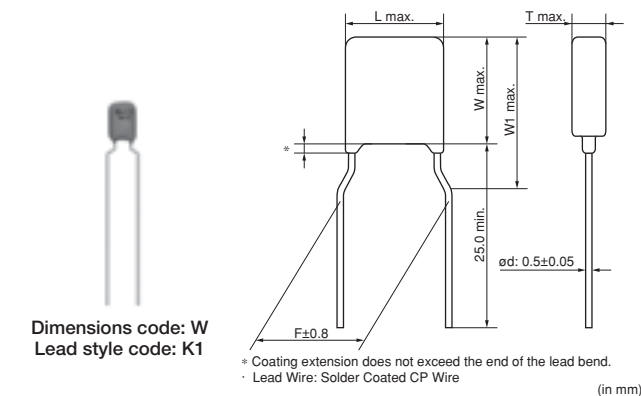
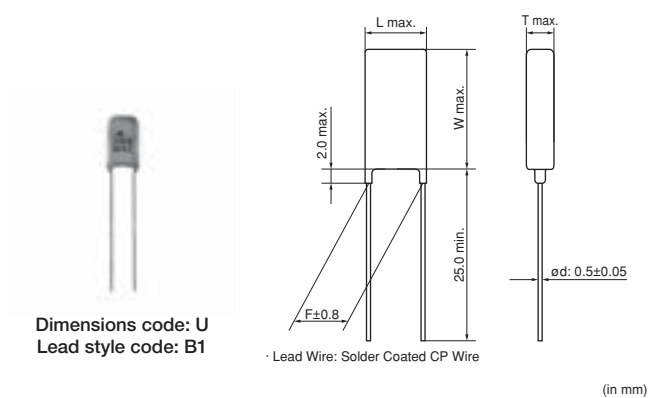
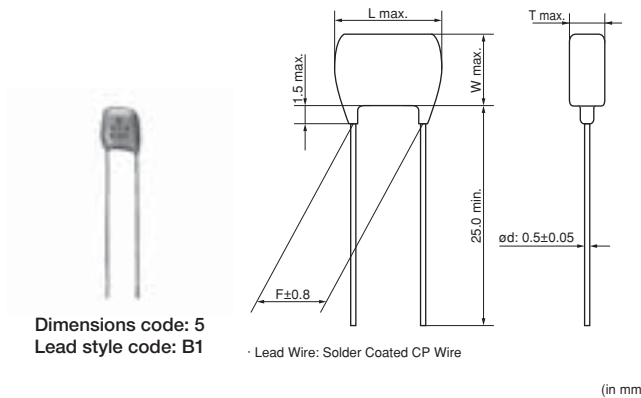
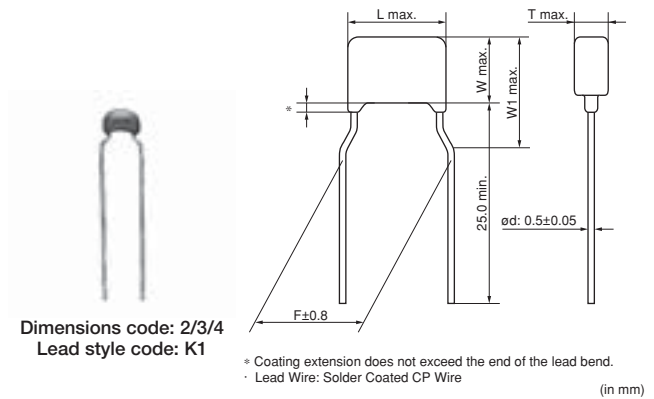
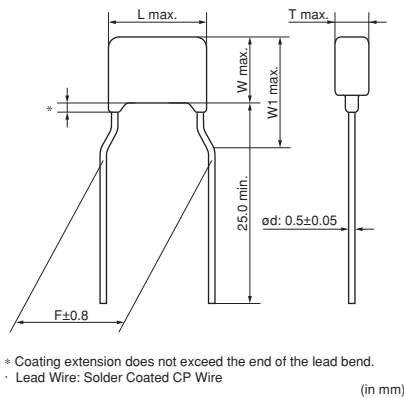
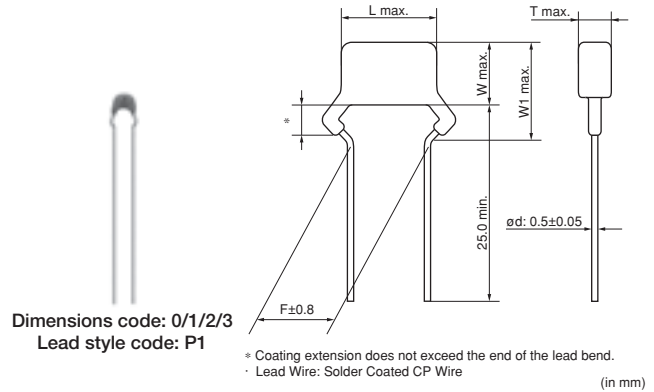

■ Dimensions

Dimensions and Lead Style Code	Dimensions (mm)					
	L	W	W1	T	F	d
0P1/0S1	5.0	3.5	6.0	See the individual product specification	2.5	0.5
0K1/0M1	4.0	3.5	6.0		5.0	0.5
1P1/1S1	5.0	3.5	5.0		2.5	0.5
1K1/1M1	4.5	3.5	5.0		5.0	0.5
2P1/2S1	5.5	4.0	6.0		2.5	0.5
2K1/2M1	5.5	4.0	6.0		5.0	0.5
3P1/3S1	5.5	5.0	7.5		2.5	0.5
3K1/3M1	5.5	5.0	7.5		5.0	0.5
4K1/4M1	7.5	5.5	8.0		5.0	0.5
5B1/5E1	7.5	7.5*	-		5.0	0.5
UB1/UE1	7.7	12.5*	-		5.0	0.5
WK1/WM1	5.5	7.5	10.0		5.0	0.5

*DC630V, DC1kV: W+0.5mm

■ Marking

Dimensions Code	Rated Voltage	DC25V		DC50V				DC100V			DC250V	DC630V	DC1kV	
		Temp. Char.	X7S	X7R	C0G	X7S	X7R	F	Y5V	C0G	X7S	X7R	X7R, U2J	
0			104K		-		473	103Z		-		-	-	-
1		224K		A 102J		224K			A 102J		224K	U 102J	-	-
2		M 475 K2C			M 475 K5C	M 105 K5C					M 105 K1C	M 103 J4U (U2J)	M 472 J7U (U2J)	M 102 JAU (U2J)
												M 473 K4C (X7R)	M 153 K7C (X7R)	M 102 KAC (X7R)
3, 4, W		M 226 K2C				M 335 K5C				M 225 K1C		M 473 J4U (U2J)	M 103 J7U (U2J)	M 472 JAU (U2J)
												M 224 K4C (X7R)	M 104 K7C (X7R)	M 333 KAC (X7R)
5, U													M 333 J7U (U2J)	M 103 JAU (U2J)
												M 474 K4C (X7R)	M 474 M7C (X7R)	M 104 KAC (X7R)
Temperature Characteristics	Marked with code (C0G char.: A, X7S/X7R char.: C, F/Y5V char.: F, U2J char.: U) A part is omitted (Please refer to the marking example.)													
Nominal Capacitance	Under 100pF: Actual value 100pF and over: Marked with 3 figures													
Capacitance Tolerance	Marked with code A part is omitted (Please refer to the marking example.)													
Rated Voltage	Marked with code (DC25V: 2, DC50V: 5, DC100V: 1, DC250V: 4, DC630V: 7, DC1kV: A) Lower horizontal line for F char. A part is omitted (Please refer to the marking example.)													
Manufacturer's Identification	Marked with M A part is omitted (Please refer to the marking example.)													

Temperature Compensating Type, C0G/U2J Characteristics

Part Number	Temp. Char.	Rated Voltage	Capacitance	Dimensions LxW (mm)	Dimension T (mm)	Lead Space F (mm)	Lead Style Code Bulk	Lead Style Code Taping
RDE5C1H1R0C0□□H03□	C0G (EIA)	50Vdc	1.0pF±0.25pF	4.0×3.5	2.5	5.0	K1	M1
RDE5C1H1R0C0□□H03□	C0G (EIA)	50Vdc	1.0pF±0.25pF	5.0×3.5	2.5	2.5	P1	S1
RDE5C1H2R0C0□□H03□	C0G (EIA)	50Vdc	2.0pF±0.25pF	4.0×3.5	2.5	5.0	K1	M1
RDE5C1H2R0C0□□H03□	C0G (EIA)	50Vdc	2.0pF±0.25pF	5.0×3.5	2.5	2.5	P1	S1
RDE5C1H3R0C0□□H03□	C0G (EIA)	50Vdc	3.0pF±0.25pF	4.0×3.5	2.5	5.0	K1	M1
RDE5C1H3R0C0□□H03□	C0G (EIA)	50Vdc	3.0pF±0.25pF	5.0×3.5	2.5	2.5	P1	S1
RDE5C1H4R0C0□□H03□	C0G (EIA)	50Vdc	4.0pF±0.25pF	4.0×3.5	2.5	5.0	K1	M1
RDE5C1H4R0C0□□H03□	C0G (EIA)	50Vdc	4.0pF±0.25pF	5.0×3.5	2.5	2.5	P1	S1
RDE5C1H5R0C0□□H03□	C0G (EIA)	50Vdc	5.0pF±0.25pF	4.0×3.5	2.5	5.0	K1	M1
RDE5C1H5R0C0□□H03□	C0G (EIA)	50Vdc	5.0pF±0.25pF	5.0×3.5	2.5	2.5	P1	S1
RDE5C1H6R0D0□□H03□	C0G (EIA)	50Vdc	6.0pF±0.5pF	4.0×3.5	2.5	5.0	K1	M1
RDE5C1H6R0D0□□H03□	C0G (EIA)	50Vdc	6.0pF±0.5pF	5.0×3.5	2.5	2.5	P1	S1
RDE5C1H7R0D0□□H03□	C0G (EIA)	50Vdc	7.0pF±0.5pF	4.0×3.5	2.5	5.0	K1	M1
RDE5C1H7R0D0□□H03□	C0G (EIA)	50Vdc	7.0pF±0.5pF	5.0×3.5	2.5	2.5	P1	S1

Continued on the following page. ↗

Continued from the preceding page.

Part Number	Temp. Char.	Rated Voltage	Capacitance	Dimensions LxW (mm)	Dimension T (mm)	Lead Space F (mm)	Lead Style Code Bulk	Lead Style Code Taping
RDE5C1H8R0D0□□H03□	C0G (EIA)	50Vdc	8.0pF±0.5pF	4.0×3.5	2.5	5.0	K1	M1
RDE5C1H8R0D0□□H03□	C0G (EIA)	50Vdc	8.0pF±0.5pF	5.0×3.5	2.5	2.5	P1	S1
RDE5C1H9R0D0□□H03□	C0G (EIA)	50Vdc	9.0pF±0.5pF	4.0×3.5	2.5	5.0	K1	M1
RDE5C1H9R0D0□□H03□	C0G (EIA)	50Vdc	9.0pF±0.5pF	5.0×3.5	2.5	2.5	P1	S1
RDE5C1H100J0□□H03□	C0G (EIA)	50Vdc	10pF±5%	4.0×3.5	2.5	5.0	K1	M1
RDE5C1H100J0□□H03□	C0G (EIA)	50Vdc	10pF±5%	5.0×3.5	2.5	2.5	P1	S1
RDE5C1H120J0□□H03□	C0G (EIA)	50Vdc	12pF±5%	4.0×3.5	2.5	5.0	K1	M1
RDE5C1H120J0□□H03□	C0G (EIA)	50Vdc	12pF±5%	5.0×3.5	2.5	2.5	P1	S1
RDE5C1H150J0□□H03□	C0G (EIA)	50Vdc	15pF±5%	4.0×3.5	2.5	5.0	K1	M1
RDE5C1H150J0□□H03□	C0G (EIA)	50Vdc	15pF±5%	5.0×3.5	2.5	2.5	P1	S1
RDE5C1H180J0□□H03□	C0G (EIA)	50Vdc	18pF±5%	4.0×3.5	2.5	5.0	K1	M1
RDE5C1H180J0□□H03□	C0G (EIA)	50Vdc	18pF±5%	5.0×3.5	2.5	2.5	P1	S1
RDE5C1H220J0□□H03□	C0G (EIA)	50Vdc	22pF±5%	4.0×3.5	2.5	5.0	K1	M1
RDE5C1H220J0□□H03□	C0G (EIA)	50Vdc	22pF±5%	5.0×3.5	2.5	2.5	P1	S1
RDE5C1H270J0□□H03□	C0G (EIA)	50Vdc	27pF±5%	4.0×3.5	2.5	5.0	K1	M1
RDE5C1H270J0□□H03□	C0G (EIA)	50Vdc	27pF±5%	5.0×3.5	2.5	2.5	P1	S1
RDE5C1H330J0□□H03□	C0G (EIA)	50Vdc	33pF±5%	4.0×3.5	2.5	5.0	K1	M1
RDE5C1H330J0□□H03□	C0G (EIA)	50Vdc	33pF±5%	5.0×3.5	2.5	2.5	P1	S1
RDE5C1H390J0□□H03□	C0G (EIA)	50Vdc	39pF±5%	4.0×3.5	2.5	5.0	K1	M1
RDE5C1H390J0□□H03□	C0G (EIA)	50Vdc	39pF±5%	5.0×3.5	2.5	2.5	P1	S1
RDE5C1H470J0□□H03□	C0G (EIA)	50Vdc	47pF±5%	4.0×3.5	2.5	5.0	K1	M1
RDE5C1H470J0□□H03□	C0G (EIA)	50Vdc	47pF±5%	5.0×3.5	2.5	2.5	P1	S1
RDE5C1H560J0□□H03□	C0G (EIA)	50Vdc	56pF±5%	4.0×3.5	2.5	5.0	K1	M1
RDE5C1H560J0□□H03□	C0G (EIA)	50Vdc	56pF±5%	5.0×3.5	2.5	2.5	P1	S1
RDE5C1H680J0□□H03□	C0G (EIA)	50Vdc	68pF±5%	4.0×3.5	2.5	5.0	K1	M1
RDE5C1H680J0□□H03□	C0G (EIA)	50Vdc	68pF±5%	5.0×3.5	2.5	2.5	P1	S1
RDE5C1H820J0□□H03□	C0G (EIA)	50Vdc	82pF±5%	4.0×3.5	2.5	5.0	K1	M1
RDE5C1H820J0□□H03□	C0G (EIA)	50Vdc	82pF±5%	5.0×3.5	2.5	2.5	P1	S1
RDE5C1H101J0□□H03□	C0G (EIA)	50Vdc	100pF±5%	4.0×3.5	2.5	5.0	K1	M1
RDE5C1H101J0□□H03□	C0G (EIA)	50Vdc	100pF±5%	5.0×3.5	2.5	2.5	P1	S1
RDE5C1H121J0□□H03□	C0G (EIA)	50Vdc	120pF±5%	4.0×3.5	2.5	5.0	K1	M1
RDE5C1H121J0□□H03□	C0G (EIA)	50Vdc	120pF±5%	5.0×3.5	2.5	2.5	P1	S1
RDE5C1H151J0□□H03□	C0G (EIA)	50Vdc	150pF±5%	4.0×3.5	2.5	5.0	K1	M1
RDE5C1H151J0□□H03□	C0G (EIA)	50Vdc	150pF±5%	5.0×3.5	2.5	2.5	P1	S1
RDE5C1H181J0□□H03□	C0G (EIA)	50Vdc	180pF±5%	4.0×3.5	2.5	5.0	K1	M1
RDE5C1H181J0□□H03□	C0G (EIA)	50Vdc	180pF±5%	5.0×3.5	2.5	2.5	P1	S1
RDE5C1H221J0□□H03□	C0G (EIA)	50Vdc	220pF±5%	4.0×3.5	2.5	5.0	K1	M1
RDE5C1H221J0□□H03□	C0G (EIA)	50Vdc	220pF±5%	5.0×3.5	2.5	2.5	P1	S1
RDE5C1H271J0□□H03□	C0G (EIA)	50Vdc	270pF±5%	4.0×3.5	2.5	5.0	K1	M1
RDE5C1H271J0□□H03□	C0G (EIA)	50Vdc	270pF±5%	5.0×3.5	2.5	2.5	P1	S1
RDE5C1H331J0□□H03□	C0G (EIA)	50Vdc	330pF±5%	4.0×3.5	2.5	5.0	K1	M1
RDE5C1H331J0□□H03□	C0G (EIA)	50Vdc	330pF±5%	5.0×3.5	2.5	2.5	P1	S1
RDE5C1H391J0□□H03□	C0G (EIA)	50Vdc	390pF±5%	4.0×3.5	2.5	5.0	K1	M1
RDE5C1H391J0□□H03□	C0G (EIA)	50Vdc	390pF±5%	5.0×3.5	2.5	2.5	P1	S1
RDE5C1H471J0□□H03□	C0G (EIA)	50Vdc	470pF±5%	4.0×3.5	2.5	5.0	K1	M1
RDE5C1H471J0□□H03□	C0G (EIA)	50Vdc	470pF±5%	5.0×3.5	2.5	2.5	P1	S1
RDE5C1H561J0□□H03□	C0G (EIA)	50Vdc	560pF±5%	4.0×3.5	2.5	5.0	K1	M1
RDE5C1H561J0□□H03□	C0G (EIA)	50Vdc	560pF±5%	5.0×3.5	2.5	2.5	P1	S1
RDE5C1H681J0□□H03□	C0G (EIA)	50Vdc	680pF±5%	4.0×3.5	2.5	5.0	K1	M1
RDE5C1H681J0□□H03□	C0G (EIA)	50Vdc	680pF±5%	5.0×3.5	2.5	2.5	P1	S1
RDE5C1H821J0□□H03□	C0G (EIA)	50Vdc	820pF±5%	4.0×3.5	2.5	5.0	K1	M1
RDE5C1H821J0□□H03□	C0G (EIA)	50Vdc	820pF±5%	5.0×3.5	2.5	2.5	P1	S1
RDE5C1H102J0□□H03□	C0G (EIA)	50Vdc	1000pF±5%	4.0×3.5	2.5	5.0	K1	M1
RDE5C1H102J0□□H03□	C0G (EIA)	50Vdc	1000pF±5%	5.0×3.5	2.5	2.5	P1	S1
RDE5C1H122J0□□H03□	C0G (EIA)	50Vdc	1200pF±5%	4.0×3.5	2.5	5.0	K1	M1
RDE5C1H122J0□□H03□	C0G (EIA)	50Vdc	1200pF±5%	5.0×3.5	2.5	2.5	P1	S1
RDE5C1H152J0□□H03□	C0G (EIA)	50Vdc	1500pF±5%	4.0×3.5	2.5	5.0	K1	M1

Continued on the following page. ↗

Continued from the preceding page.

Part Number	Temp. Char.	Rated Voltage	Capacitance	Dimensions LxW (mm)	Dimension T (mm)	Lead Space F (mm)	Lead Style Code Bulk	Lead Style Code Taping
RDE5C1H152J0□□H03□	C0G (EIA)	50Vdc	1500pF±5%	5.0×3.5	2.5	2.5	P1	S1
RDE5C1H182J0□□H03□	C0G (EIA)	50Vdc	1800pF±5%	4.0×3.5	2.5	5.0	K1	M1
RDE5C1H182J0□□H03□	C0G (EIA)	50Vdc	1800pF±5%	5.0×3.5	2.5	2.5	P1	S1
RDE5C1H222J0□□H03□	C0G (EIA)	50Vdc	2200pF±5%	4.0×3.5	2.5	5.0	K1	M1
RDE5C1H222J0□□H03□	C0G (EIA)	50Vdc	2200pF±5%	5.0×3.5	2.5	2.5	P1	S1
RDE5C1H272J0□□H03□	C0G (EIA)	50Vdc	2700pF±5%	4.0×3.5	2.5	5.0	K1	M1
RDE5C1H272J0□□H03□	C0G (EIA)	50Vdc	2700pF±5%	5.0×3.5	2.5	2.5	P1	S1
RDE5C1H332J0□□H03□	C0G (EIA)	50Vdc	3300pF±5%	4.0×3.5	2.5	5.0	K1	M1
RDE5C1H332J0□□H03□	C0G (EIA)	50Vdc	3300pF±5%	5.0×3.5	2.5	2.5	P1	S1
RDE5C1H392J0□□H03□	C0G (EIA)	50Vdc	3900pF±5%	4.0×3.5	2.5	5.0	K1	M1
RDE5C1H392J0□□H03□	C0G (EIA)	50Vdc	3900pF±5%	5.0×3.5	2.5	2.5	P1	S1
RDE5C1H472J1□□H03□	C0G (EIA)	50Vdc	4700pF±5%	4.5×3.5	3.15	5.0	K1	M1
RDE5C1H472J1□□H03□	C0G (EIA)	50Vdc	4700pF±5%	5.0×3.5	3.15	2.5	P1	S1
RDE5C1H562J1□□H03□	C0G (EIA)	50Vdc	5600pF±5%	4.5×3.5	3.15	5.0	K1	M1
RDE5C1H562J1□□H03□	C0G (EIA)	50Vdc	5600pF±5%	5.0×3.5	3.15	2.5	P1	S1
RDE5C1H682J1□□H03□	C0G (EIA)	50Vdc	6800pF±5%	4.5×3.5	3.15	5.0	K1	M1
RDE5C1H682J1□□H03□	C0G (EIA)	50Vdc	6800pF±5%	5.0×3.5	3.15	2.5	P1	S1
RDE5C1H822J1□□H03□	C0G (EIA)	50Vdc	8200pF±5%	4.5×3.5	3.15	5.0	K1	M1
RDE5C1H822J1□□H03□	C0G (EIA)	50Vdc	8200pF±5%	5.0×3.5	3.15	2.5	P1	S1
RDE5C1H103J1□□H03□	C0G (EIA)	50Vdc	10000pF±5%	4.5×3.5	3.15	5.0	K1	M1
RDE5C1H103J1□□H03□	C0G (EIA)	50Vdc	10000pF±5%	5.0×3.5	3.15	2.5	P1	S1
RDE5C1H123J1□□H03□	C0G (EIA)	50Vdc	12000pF±5%	4.5×3.5	3.15	5.0	K1	M1
RDE5C1H123J1□□H03□	C0G (EIA)	50Vdc	12000pF±5%	5.0×3.5	3.15	2.5	P1	S1
RDE5C1H153J1□□H03□	C0G (EIA)	50Vdc	15000pF±5%	4.5×3.5	3.15	5.0	K1	M1
RDE5C1H153J1□□H03□	C0G (EIA)	50Vdc	15000pF±5%	5.0×3.5	3.15	2.5	P1	S1
RDE5C1H183J1□□H03□	C0G (EIA)	50Vdc	18000pF±5%	4.5×3.5	3.15	5.0	K1	M1
RDE5C1H183J1□□H03□	C0G (EIA)	50Vdc	18000pF±5%	5.0×3.5	3.15	2.5	P1	S1
RDE5C1H223J1□□H03□	C0G (EIA)	50Vdc	22000pF±5%	4.5×3.5	3.15	5.0	K1	M1
RDE5C1H223J1□□H03□	C0G (EIA)	50Vdc	22000pF±5%	5.0×3.5	3.15	2.5	P1	S1
RDE5C2A1R0C0□□H03□	C0G (EIA)	100Vdc	1.0pF±0.25pF	4.0×3.5	2.5	5.0	K1	M1
RDE5C2A1R0C0□□H03□	C0G (EIA)	100Vdc	1.0pF±0.25pF	5.0×3.5	2.5	2.5	P1	S1
RDE5C2A2R0C0□□H03□	C0G (EIA)	100Vdc	2.0pF±0.25pF	4.0×3.5	2.5	5.0	K1	M1
RDE5C2A2R0C0□□H03□	C0G (EIA)	100Vdc	2.0pF±0.25pF	5.0×3.5	2.5	2.5	P1	S1
RDE5C2A3R0C0□□H03□	C0G (EIA)	100Vdc	3.0pF±0.25pF	4.0×3.5	2.5	5.0	K1	M1
RDE5C2A3R0C0□□H03□	C0G (EIA)	100Vdc	3.0pF±0.25pF	5.0×3.5	2.5	2.5	P1	S1
RDE5C2A4R0C0□□H03□	C0G (EIA)	100Vdc	4.0pF±0.25pF	4.0×3.5	2.5	5.0	K1	M1
RDE5C2A4R0C0□□H03□	C0G (EIA)	100Vdc	4.0pF±0.25pF	5.0×3.5	2.5	2.5	P1	S1
RDE5C2A5R0C0□□H03□	C0G (EIA)	100Vdc	5.0pF±0.25pF	4.0×3.5	2.5	5.0	K1	M1
RDE5C2A5R0C0□□H03□	C0G (EIA)	100Vdc	5.0pF±0.25pF	5.0×3.5	2.5	2.5	P1	S1
RDE5C2A6R0D0□□H03□	C0G (EIA)	100Vdc	6.0pF±0.5pF	4.0×3.5	2.5	5.0	K1	M1
RDE5C2A6R0D0□□H03□	C0G (EIA)	100Vdc	6.0pF±0.5pF	5.0×3.5	2.5	2.5	P1	S1
RDE5C2A7R0D0□□H03□	C0G (EIA)	100Vdc	7.0pF±0.5pF	4.0×3.5	2.5	5.0	K1	M1
RDE5C2A7R0D0□□H03□	C0G (EIA)	100Vdc	7.0pF±0.5pF	5.0×3.5	2.5	2.5	P1	S1
RDE5C2A8R0D0□□H03□	C0G (EIA)	100Vdc	8.0pF±0.5pF	4.0×3.5	2.5	5.0	K1	M1
RDE5C2A8R0D0□□H03□	C0G (EIA)	100Vdc	8.0pF±0.5pF	5.0×3.5	2.5	2.5	P1	S1
RDE5C2A9R0D0□□H03□	C0G (EIA)	100Vdc	9.0pF±0.5pF	4.0×3.5	2.5	5.0	K1	M1
RDE5C2A9R0D0□□H03□	C0G (EIA)	100Vdc	9.0pF±0.5pF	5.0×3.5	2.5	2.5	P1	S1
RDE5C2A100J0□□H03□	C0G (EIA)	100Vdc	10pF±5%	4.0×3.5	2.5	5.0	K1	M1
RDE5C2A100J0□□H03□	C0G (EIA)	100Vdc	10pF±5%	5.0×3.5	2.5	2.5	P1	S1
RDE5C2A120J0□□H03□	C0G (EIA)	100Vdc	12pF±5%	4.0×3.5	2.5	5.0	K1	M1
RDE5C2A120J0□□H03□	C0G (EIA)	100Vdc	12pF±5%	5.0×3.5	2.5	2.5	P1	S1
RDE5C2A150J0□□H03□	C0G (EIA)	100Vdc	15pF±5%	4.0×3.5	2.5	5.0	K1	M1
RDE5C2A150J0□□H03□	C0G (EIA)	100Vdc	15pF±5%	5.0×3.5	2.5	2.5	P1	S1
RDE5C2A180J0□□H03□	C0G (EIA)	100Vdc	18pF±5%	4.0×3.5	2.5	5.0	K1	M1
RDE5C2A180J0□□H03□	C0G (EIA)	100Vdc	18pF±5%	5.0×3.5	2.5	2.5	P1	S1
RDE5C2A220J0□□H03□	C0G (EIA)	100Vdc	22pF±5%	4.0×3.5	2.5	5.0	K1	M1
RDE5C2A220J0□□H03□	C0G (EIA)	100Vdc	22pF±5%	5.0×3.5	2.5	2.5	P1	S1

Continued on the following page. ↗

Continued from the preceding page.

Part Number	Temp. Char.	Rated Voltage	Capacitance	Dimensions LxW (mm)	Dimension T (mm)	Lead Space F (mm)	Lead Style Code Bulk	Lead Style Code Taping
RDE5C2A270J0□□H03□	C0G (EIA)	100Vdc	27pF±5%	4.0×3.5	2.5	5.0	K1	M1
RDE5C2A270J0□□H03□	C0G (EIA)	100Vdc	27pF±5%	5.0×3.5	2.5	2.5	P1	S1
RDE5C2A330J0□□H03□	C0G (EIA)	100Vdc	33pF±5%	4.0×3.5	2.5	5.0	K1	M1
RDE5C2A330J0□□H03□	C0G (EIA)	100Vdc	33pF±5%	5.0×3.5	2.5	2.5	P1	S1
RDE5C2A390J0□□H03□	C0G (EIA)	100Vdc	39pF±5%	4.0×3.5	2.5	5.0	K1	M1
RDE5C2A390J0□□H03□	C0G (EIA)	100Vdc	39pF±5%	5.0×3.5	2.5	2.5	P1	S1
RDE5C2A470J0□□H03□	C0G (EIA)	100Vdc	47pF±5%	4.0×3.5	2.5	5.0	K1	M1
RDE5C2A470J0□□H03□	C0G (EIA)	100Vdc	47pF±5%	5.0×3.5	2.5	2.5	P1	S1
RDE5C2A560J0□□H03□	C0G (EIA)	100Vdc	56pF±5%	4.0×3.5	2.5	5.0	K1	M1
RDE5C2A560J0□□H03□	C0G (EIA)	100Vdc	56pF±5%	5.0×3.5	2.5	2.5	P1	S1
RDE5C2A680J0□□H03□	C0G (EIA)	100Vdc	68pF±5%	4.0×3.5	2.5	5.0	K1	M1
RDE5C2A680J0□□H03□	C0G (EIA)	100Vdc	68pF±5%	5.0×3.5	2.5	2.5	P1	S1
RDE5C2A820J0□□H03□	C0G (EIA)	100Vdc	82pF±5%	4.0×3.5	2.5	5.0	K1	M1
RDE5C2A820J0□□H03□	C0G (EIA)	100Vdc	82pF±5%	5.0×3.5	2.5	2.5	P1	S1
RDE5C2A101J0□□H03□	C0G (EIA)	100Vdc	100pF±5%	4.0×3.5	2.5	5.0	K1	M1
RDE5C2A101J0□□H03□	C0G (EIA)	100Vdc	100pF±5%	5.0×3.5	2.5	2.5	P1	S1
RDE5C2A121J0□□H03□	C0G (EIA)	100Vdc	120pF±5%	4.0×3.5	2.5	5.0	K1	M1
RDE5C2A121J0□□H03□	C0G (EIA)	100Vdc	120pF±5%	5.0×3.5	2.5	2.5	P1	S1
RDE5C2A151J0□□H03□	C0G (EIA)	100Vdc	150pF±5%	4.0×3.5	2.5	5.0	K1	M1
RDE5C2A151J0□□H03□	C0G (EIA)	100Vdc	150pF±5%	5.0×3.5	2.5	2.5	P1	S1
RDE5C2A181J0□□H03□	C0G (EIA)	100Vdc	180pF±5%	4.0×3.5	2.5	5.0	K1	M1
RDE5C2A181J0□□H03□	C0G (EIA)	100Vdc	180pF±5%	5.0×3.5	2.5	2.5	P1	S1
RDE5C2A221J0□□H03□	C0G (EIA)	100Vdc	220pF±5%	4.0×3.5	2.5	5.0	K1	M1
RDE5C2A221J0□□H03□	C0G (EIA)	100Vdc	220pF±5%	5.0×3.5	2.5	2.5	P1	S1
RDE5C2A271J0□□H03□	C0G (EIA)	100Vdc	270pF±5%	4.0×3.5	2.5	5.0	K1	M1
RDE5C2A271J0□□H03□	C0G (EIA)	100Vdc	270pF±5%	5.0×3.5	2.5	2.5	P1	S1
RDE5C2A331J0□□H03□	C0G (EIA)	100Vdc	330pF±5%	4.0×3.5	2.5	5.0	K1	M1
RDE5C2A331J0□□H03□	C0G (EIA)	100Vdc	330pF±5%	5.0×3.5	2.5	2.5	P1	S1
RDE5C2A391J0□□H03□	C0G (EIA)	100Vdc	390pF±5%	4.0×3.5	2.5	5.0	K1	M1
RDE5C2A391J0□□H03□	C0G (EIA)	100Vdc	390pF±5%	5.0×3.5	2.5	2.5	P1	S1
RDE5C2A471J0□□H03□	C0G (EIA)	100Vdc	470pF±5%	4.0×3.5	2.5	5.0	K1	M1
RDE5C2A471J0□□H03□	C0G (EIA)	100Vdc	470pF±5%	5.0×3.5	2.5	2.5	P1	S1
RDE5C2A561J0□□H03□	C0G (EIA)	100Vdc	560pF±5%	4.0×3.5	2.5	5.0	K1	M1
RDE5C2A561J0□□H03□	C0G (EIA)	100Vdc	560pF±5%	5.0×3.5	2.5	2.5	P1	S1
RDE5C2A681J0□□H03□	C0G (EIA)	100Vdc	680pF±5%	4.0×3.5	2.5	5.0	K1	M1
RDE5C2A681J0□□H03□	C0G (EIA)	100Vdc	680pF±5%	5.0×3.5	2.5	2.5	P1	S1
RDE5C2A821J0□□H03□	C0G (EIA)	100Vdc	820pF±5%	4.0×3.5	2.5	5.0	K1	M1
RDE5C2A821J0□□H03□	C0G (EIA)	100Vdc	820pF±5%	5.0×3.5	2.5	2.5	P1	S1
RDE5C2A102J0□□H03□	C0G (EIA)	100Vdc	1000pF±5%	4.0×3.5	2.5	5.0	K1	M1
RDE5C2A102J0□□H03□	C0G (EIA)	100Vdc	1000pF±5%	5.0×3.5	2.5	2.5	P1	S1
RDE5C2A122J0□□H03□	C0G (EIA)	100Vdc	1200pF±5%	4.0×3.5	2.5	5.0	K1	M1
RDE5C2A122J0□□H03□	C0G (EIA)	100Vdc	1200pF±5%	5.0×3.5	2.5	2.5	P1	S1
RDE5C2A152J0□□H03□	C0G (EIA)	100Vdc	1500pF±5%	4.0×3.5	2.5	5.0	K1	M1
RDE5C2A152J0□□H03□	C0G (EIA)	100Vdc	1500pF±5%	5.0×3.5	2.5	2.5	P1	S1
RDE5C2A182J1□□H03□	C0G (EIA)	100Vdc	1800pF±5%	4.5×3.5	3.15	5.0	K1	M1
RDE5C2A182J1□□H03□	C0G (EIA)	100Vdc	1800pF±5%	5.0×3.5	3.15	2.5	P1	S1
RDE5C2A222J1□□H03□	C0G (EIA)	100Vdc	2200pF±5%	4.5×3.5	3.15	5.0	K1	M1
RDE5C2A222J1□□H03□	C0G (EIA)	100Vdc	2200pF±5%	5.0×3.5	3.15	2.5	P1	S1
RDE5C2A272J1□□H03□	C0G (EIA)	100Vdc	2700pF±5%	4.5×3.5	3.15	5.0	K1	M1
RDE5C2A272J1□□H03□	C0G (EIA)	100Vdc	2700pF±5%	5.0×3.5	3.15	2.5	P1	S1
RDE5C2A332J1□□H03□	C0G (EIA)	100Vdc	3300pF±5%	4.5×3.5	3.15	5.0	K1	M1
RDE5C2A332J1□□H03□	C0G (EIA)	100Vdc	3300pF±5%	5.0×3.5	3.15	2.5	P1	S1
RDE7U2E101J1□□H03□	U2J (EIA)	250Vdc	100pF±5%	4.5×3.5	3.15	5.0	K1	M1
RDE7U2E151J1□□H03□	U2J (EIA)	250Vdc	150pF±5%	4.5×3.5	3.15	5.0	K1	M1
RDE7U2E221J1□□H03□	U2J (EIA)	250Vdc	220pF±5%	4.5×3.5	3.15	5.0	K1	M1
RDE7U2E331J1□□H03□	U2J (EIA)	250Vdc	330pF±5%	4.5×3.5	3.15	5.0	K1	M1
RDE7U2E471J1□□H03□	U2J (EIA)	250Vdc	470pF±5%	4.5×3.5	3.15	5.0	K1	M1

Continued on the following page. ↗

Continued from the preceding page.

Part Number	Temp. Char.	Rated Voltage	Capacitance	Dimensions LxW (mm)	Dimension T (mm)	Lead Space F (mm)	Lead Style Code Bulk	Lead Style Code Taping
RDE7U2E681J1□□H03□	U2J (EIA)	250Vdc	680pF±5%	4.5×3.5	3.15	5.0	K1	M1
RDE7U2E102J1□□H03□	U2J (EIA)	250Vdc	1000pF±5%	4.5×3.5	3.15	5.0	K1	M1
RDE7U2E152J1□□H03□	U2J (EIA)	250Vdc	1500pF±5%	4.5×3.5	3.15	5.0	K1	M1
RDE7U2E222J1□□H03□	U2J (EIA)	250Vdc	2200pF±5%	4.5×3.5	3.15	5.0	K1	M1
RDE7U2E332J1□□H03□	U2J (EIA)	250Vdc	3300pF±5%	4.5×3.5	3.15	5.0	K1	M1
RDE7U2E472J1□□H03□	U2J (EIA)	250Vdc	4700pF±5%	4.5×3.5	3.15	5.0	K1	M1
RDE7U2E682J2□□H03□	U2J (EIA)	250Vdc	6800pF±5%	5.5×4.0	3.15	5.0	K1	M1
RDE7U2E103J2□□H03□	U2J (EIA)	250Vdc	10000pF±5%	5.5×4.0	3.15	5.0	K1	M1
RDE7U2E153J2□□H03□	U2J (EIA)	250Vdc	15000pF±5%	5.5×4.0	3.15	5.0	K1	M1
RDE7U2E223J2□□H03□	U2J (EIA)	250Vdc	22000pF±5%	5.5×4.0	3.15	5.0	K1	M1
RDE7U2E333J3□□H03□	U2J (EIA)	250Vdc	33000pF±5%	5.5×5.0	4.0	5.0	K1	M1
RDE7U2E473J3□□H03□	U2J (EIA)	250Vdc	47000pF±5%	5.5×5.0	4.0	5.0	K1	M1
RDE7U2J100J2□□H03□	U2J (EIA)	630Vdc	10pF±5%	5.5×4.0	3.15	5.0	K1	M1
RDE7U2J150J2□□H03□	U2J (EIA)	630Vdc	15pF±5%	5.5×4.0	3.15	5.0	K1	M1
RDE7U2J220J2□□H03□	U2J (EIA)	630Vdc	22pF±5%	5.5×4.0	3.15	5.0	K1	M1
RDE7U2J330J2□□H03□	U2J (EIA)	630Vdc	33pF±5%	5.5×4.0	3.15	5.0	K1	M1
RDE7U2J470J2□□H03□	U2J (EIA)	630Vdc	47pF±5%	5.5×4.0	3.15	5.0	K1	M1
RDE7U2J680J2□□H03□	U2J (EIA)	630Vdc	68pF±5%	5.5×4.0	3.15	5.0	K1	M1
RDE7U2J101J2□□H03□	U2J (EIA)	630Vdc	100pF±5%	5.5×4.0	3.15	5.0	K1	M1
RDE7U2J151J2□□H03□	U2J (EIA)	630Vdc	150pF±5%	5.5×4.0	3.15	5.0	K1	M1
RDE7U2J221J2□□H03□	U2J (EIA)	630Vdc	220pF±5%	5.5×4.0	3.15	5.0	K1	M1
RDE7U2J331J2□□H03□	U2J (EIA)	630Vdc	330pF±5%	5.5×4.0	3.15	5.0	K1	M1
RDE7U2J471J2□□H03□	U2J (EIA)	630Vdc	470pF±5%	5.5×4.0	3.15	5.0	K1	M1
RDE7U2J681J2□□H03□	U2J (EIA)	630Vdc	680pF±5%	5.5×4.0	3.15	5.0	K1	M1
RDE7U2J102J2□□H03□	U2J (EIA)	630Vdc	1000pF±5%	5.5×4.0	3.15	5.0	K1	M1
RDE7U2J152J2□□H03□	U2J (EIA)	630Vdc	1500pF±5%	5.5×4.0	3.15	5.0	K1	M1
RDE7U2J222J2□□H03□	U2J (EIA)	630Vdc	2200pF±5%	5.5×4.0	3.15	5.0	K1	M1
RDE7U2J332J2□□H03□	U2J (EIA)	630Vdc	3300pF±5%	5.5×4.0	3.15	5.0	K1	M1
RDE7U2J472J2□□H03□	U2J (EIA)	630Vdc	4700pF±5%	5.5×4.0	3.15	5.0	K1	M1
RDE7U2J682J3□□H03□	U2J (EIA)	630Vdc	6800pF±5%	5.5×5.0	4.0	5.0	K1	M1
RDE7U2J103J3□□H03□	U2J (EIA)	630Vdc	10000pF±5%	5.5×5.0	4.0	5.0	K1	M1
RDE7U2J153J4□□H03□	U2J (EIA)	630Vdc	15000pF±5%	7.5×5.5	4.0	5.0	K1	M1
RDE7U2J223J4□□H03□	U2J (EIA)	630Vdc	22000pF±5%	7.5×5.5	4.0	5.0	K1	M1
RDE7U2J333J5□□H03□	U2J (EIA)	630Vdc	33000pF±5%	7.5×8.0	4.0	5.0	B1	E1
RDE7U2J473J5□□H03□	U2J (EIA)	630Vdc	47000pF±5%	7.5×8.0	4.0	5.0	B1	E1
RDE7U2J943JU□□H03□	U2J (EIA)	630Vdc	94000pF±5%	7.7×13.0	4.0	5.0	B1	E1
RDE7U3A100J2□□H03□	U2J (EIA)	1000Vdc	10pF±5%	5.5×4.0	3.15	5.0	K1	M1
RDE7U3A150J2□□H03□	U2J (EIA)	1000Vdc	15pF±5%	5.5×4.0	3.15	5.0	K1	M1
RDE7U3A220J2□□H03□	U2J (EIA)	1000Vdc	22pF±5%	5.5×4.0	3.15	5.0	K1	M1
RDE7U3A330J2□□H03□	U2J (EIA)	1000Vdc	33pF±5%	5.5×4.0	3.15	5.0	K1	M1
RDE7U3A470J2□□H03□	U2J (EIA)	1000Vdc	47pF±5%	5.5×4.0	3.15	5.0	K1	M1
RDE7U3A680J2□□H03□	U2J (EIA)	1000Vdc	68pF±5%	5.5×4.0	3.15	5.0	K1	M1
RDE7U3A101J2□□H03□	U2J (EIA)	1000Vdc	100pF±5%	5.5×4.0	3.15	5.0	K1	M1
RDE7U3A151J2□□H03□	U2J (EIA)	1000Vdc	150pF±5%	5.5×4.0	3.15	5.0	K1	M1
RDE7U3A221J2□□H03□	U2J (EIA)	1000Vdc	220pF±5%	5.5×4.0	3.15	5.0	K1	M1
RDE7U3A331J2□□H03□	U2J (EIA)	1000Vdc	330pF±5%	5.5×4.0	3.15	5.0	K1	M1
RDE7U3A471J2□□H03□	U2J (EIA)	1000Vdc	470pF±5%	5.5×4.0	3.15	5.0	K1	M1
RDE7U3A681J2□□H03□	U2J (EIA)	1000Vdc	680pF±5%	5.5×4.0	3.15	5.0	K1	M1
RDE7U3A102J2□□H03□	U2J (EIA)	1000Vdc	1000pF±5%	5.5×4.0	3.15	5.0	K1	M1
RDE7U3A152J3□□H03□	U2J (EIA)	1000Vdc	1500pF±5%	5.5×5.0	4.0	5.0	K1	M1
RDE7U3A222J3□□H03□	U2J (EIA)	1000Vdc	2200pF±5%	5.5×5.0	4.0	5.0	K1	M1
RDE7U3A332J4□□H03□	U2J (EIA)	1000Vdc	3300pF±5%	7.5×5.5	4.0	5.0	K1	M1
RDE7U3A472J4□□H03□	U2J (EIA)	1000Vdc	4700pF±5%	7.5×5.5	4.0	5.0	K1	M1
RDE7U3A682J5□□H03□	U2J (EIA)	1000Vdc	6800pF±5%	7.5×8.0	4.0	5.0	B1	E1
RDE7U3A103J5□□H03□	U2J (EIA)	1000Vdc	10000pF±5%	7.5×8.0	4.0	5.0	B1	E1
RDE7U3A203JU□□H03□	U2J (EIA)	1000Vdc	20000pF±5%	7.7×13.0	4.0	5.0	B1	E1

Two blank columns are filled with the lead style code. Please refer to the 3 columns on the right for the appropriate code.

The last blank column is filled with the packaging code. (B: bulk, A: ammo pack)

High Dielectric Constant Type, X7R/X7S Characteristics

Part Number	Temp. Char.	Rated Voltage	Capacitance	Dimensions LxW (mm)	Dimension T (mm)	Lead Space F (mm)	Lead Style Code Bulk	Lead Style Code Taping
RDER71E104K0□□H03□	X7R (EIA)	25Vdc	0.1μF±10%	4.0×3.5	2.5	5.0	K1	M1
RDER71E104K0□□H03□	X7R (EIA)	25Vdc	0.1μF±10%	5.0×3.5	2.5	2.5	P1	S1
RDEC71E224K0□□H03□	X7S (EIA)	25Vdc	0.22μF±10%	4.0×3.5	2.5	5.0	K1	M1
RDEC71E224K0□□H03□	X7S (EIA)	25Vdc	0.22μF±10%	5.0×3.5	2.5	2.5	P1	S1
RDEC71E474K0□□H03□	X7S (EIA)	25Vdc	0.47μF±10%	4.0×3.5	2.5	5.0	K1	M1
RDEC71E474K0□□H03□	X7S (EIA)	25Vdc	0.47μF±10%	5.0×3.5	2.5	2.5	P1	S1
RDEC71E105K0□□H03□	X7S (EIA)	25Vdc	1.0μF±10%	4.0×3.5	2.5	5.0	K1	M1
RDEC71E105K0□□H03□	X7S (EIA)	25Vdc	1.0μF±10%	5.0×3.5	2.5	2.5	P1	S1
RDEC71E225K1□□H03□	X7S (EIA)	25Vdc	2.2μF±10%	4.5×3.5	3.15	5.0	K1	M1
RDEC71E225K1□□H03□	X7S (EIA)	25Vdc	2.2μF±10%	5.0×3.5	3.15	2.5	P1	S1
RDEC71E475K2□□H03□	X7S (EIA)	25Vdc	4.7μF±10%	5.5×4.0	3.15	2.5	P1	S1
RDEC71E475K2□□H03□	X7S (EIA)	25Vdc	4.7μF±10%	5.5×4.0	3.15	5.0	K1	M1
RDEC71E106K2□□H03□	X7S (EIA)	25Vdc	10μF±10%	5.5×4.0	3.15	2.5	P1	S1
RDEC71E106K2□□H03□	X7S (EIA)	25Vdc	10μF±10%	5.5×4.0	3.15	5.0	K1	M1
RDEC71E226K3□□H03□	X7S (EIA)	25Vdc	22μF±10%	5.5×5.0	4.0	2.5	P1	S1
RDEC71E226K3□□H03□	X7S (EIA)	25Vdc	22μF±10%	5.5×5.0	4.0	5.0	K1	M1
RDEC71E476MW□□H03□	X7S (EIA)	25Vdc	47μF±20%	5.5×7.5	4.0	5.0	K1	M1
RDER71H221K0□□H03□	X7R (EIA)	50Vdc	220pF±10%	4.0×3.5	2.5	5.0	K1	M1
RDER71H221K0□□H03□	X7R (EIA)	50Vdc	220pF±10%	5.0×3.5	2.5	2.5	P1	S1
RDER71H331K0□□H03□	X7R (EIA)	50Vdc	330pF±10%	4.0×3.5	2.5	5.0	K1	M1
RDER71H331K0□□H03□	X7R (EIA)	50Vdc	330pF±10%	5.0×3.5	2.5	2.5	P1	S1
RDER71H471K0□□H03□	X7R (EIA)	50Vdc	470pF±10%	4.0×3.5	2.5	5.0	K1	M1
RDER71H471K0□□H03□	X7R (EIA)	50Vdc	470pF±10%	5.0×3.5	2.5	2.5	P1	S1
RDER71H681K0□□H03□	X7R (EIA)	50Vdc	680pF±10%	4.0×3.5	2.5	5.0	K1	M1
RDER71H681K0□□H03□	X7R (EIA)	50Vdc	680pF±10%	5.0×3.5	2.5	2.5	P1	S1
RDER71H102K0□□H03□	X7R (EIA)	50Vdc	1000pF±10%	4.0×3.5	2.5	5.0	K1	M1
RDER71H102K0□□H03□	X7R (EIA)	50Vdc	1000pF±10%	5.0×3.5	2.5	2.5	P1	S1
RDER71H152K0□□H03□	X7R (EIA)	50Vdc	1500pF±10%	4.0×3.5	2.5	5.0	K1	M1
RDER71H152K0□□H03□	X7R (EIA)	50Vdc	1500pF±10%	5.0×3.5	2.5	2.5	P1	S1
RDER71H222K0□□H03□	X7R (EIA)	50Vdc	2200pF±10%	4.0×3.5	2.5	5.0	K1	M1
RDER71H222K0□□H03□	X7R (EIA)	50Vdc	2200pF±10%	5.0×3.5	2.5	2.5	P1	S1
RDER71H332K0□□H03□	X7R (EIA)	50Vdc	3300pF±10%	4.0×3.5	2.5	5.0	K1	M1
RDER71H332K0□□H03□	X7R (EIA)	50Vdc	3300pF±10%	5.0×3.5	2.5	2.5	P1	S1
RDER71H472K0□□H03□	X7R (EIA)	50Vdc	4700pF±10%	4.0×3.5	2.5	5.0	K1	M1
RDER71H472K0□□H03□	X7R (EIA)	50Vdc	4700pF±10%	5.0×3.5	2.5	2.5	P1	S1
RDER71H682K0□□H03□	X7R (EIA)	50Vdc	6800pF±10%	4.0×3.5	2.5	5.0	K1	M1
RDER71H682K0□□H03□	X7R (EIA)	50Vdc	6800pF±10%	5.0×3.5	2.5	2.5	P1	S1
RDER71H103K0□□H03□	X7R (EIA)	50Vdc	10000pF±10%	4.0×3.5	2.5	5.0	K1	M1
RDER71H103K0□□H03□	X7R (EIA)	50Vdc	10000pF±10%	5.0×3.5	2.5	2.5	P1	S1
RDER71H153K0□□H03□	X7R (EIA)	50Vdc	15000pF±10%	4.0×3.5	2.5	5.0	K1	M1
RDER71H153K0□□H03□	X7R (EIA)	50Vdc	15000pF±10%	5.0×3.5	2.5	2.5	P1	S1
RDER71H223K0□□H03□	X7R (EIA)	50Vdc	22000pF±10%	4.0×3.5	2.5	5.0	K1	M1
RDER71H223K0□□H03□	X7R (EIA)	50Vdc	22000pF±10%	5.0×3.5	2.5	2.5	P1	S1
RDER71H333K0□□H03□	X7R (EIA)	50Vdc	33000pF±10%	4.0×3.5	2.5	5.0	K1	M1
RDER71H333K0□□H03□	X7R (EIA)	50Vdc	33000pF±10%	5.0×3.5	2.5	2.5	P1	S1
RDER71H473K0□□H03□	X7R (EIA)	50Vdc	47000pF±10%	4.0×3.5	2.5	5.0	K1	M1
RDER71H473K0□□H03□	X7R (EIA)	50Vdc	47000pF±10%	5.0×3.5	2.5	2.5	P1	S1
RDER71H683K0□□H03□	X7R (EIA)	50Vdc	68000pF±10%	4.0×3.5	2.5	5.0	K1	M1
RDER71H683K0□□H03□	X7R (EIA)	50Vdc	68000pF±10%	5.0×3.5	2.5	2.5	P1	S1
RDER71H104K0□□H03□	X7R (EIA)	50Vdc	0.1μF±10%	4.0×3.5	2.5	5.0	K1	M1
RDER71H104K0□□H03□	X7R (EIA)	50Vdc	0.1μF±10%	5.0×3.5	2.5	2.5	P1	S1
RDER71H154K1□□H03□	X7R (EIA)	50Vdc	0.15μF±10%	4.5×3.5	3.15	5.0	K1	M1
RDER71H154K1□□H03□	X7R (EIA)	50Vdc	0.15μF±10%	5.0×3.5	3.15	2.5	P1	S1
RDER71H224K1□□H03□	X7R (EIA)	50Vdc	0.22μF±10%	4.5×3.5	3.15	5.0	K1	M1
RDER71H224K1□□H03□	X7R (EIA)	50Vdc	0.22μF±10%	5.0×3.5	3.15	2.5	P1	S1

Continued on the following page. 

Continued from the preceding page.

Part Number	Temp. Char.	Rated Voltage	Capacitance	Dimensions LxW (mm)	Dimension T (mm)	Lead Space F (mm)	Lead Style Code Bulk	Lead Style Code Taping
RDER71H334K1□□H03□	X7R (EIA)	50Vdc	0.33μF±10%	4.5×3.5	3.15	5.0	K1	M1
RDER71H334K1□□H03□	X7R (EIA)	50Vdc	0.33μF±10%	5.0×3.5	3.15	2.5	P1	S1
RDER71H474K1□□H03□	X7R (EIA)	50Vdc	0.47μF±10%	4.5×3.5	3.15	5.0	K1	M1
RDER71H474K1□□H03□	X7R (EIA)	50Vdc	0.47μF±10%	5.0×3.5	3.15	2.5	P1	S1
RDER71H684K2□□H03□	X7R (EIA)	50Vdc	0.68μF±10%	5.5×4.0	3.15	2.5	P1	S1
RDER71H684K2□□H03□	X7R (EIA)	50Vdc	0.68μF±10%	5.5×4.0	3.15	5.0	K1	M1
RDER71H105K2□□H03□	X7R (EIA)	50Vdc	1.0μF±10%	5.5×4.0	3.15	2.5	P1	S1
RDER71H105K2□□H03□	X7R (EIA)	50Vdc	1.0μF±10%	5.5×4.0	3.15	5.0	K1	M1
RDER71H155K2□□H03□	X7R (EIA)	50Vdc	1.5μF±10%	5.5×4.0	3.15	2.5	P1	S1
RDER71H155K2□□H03□	X7R (EIA)	50Vdc	1.5μF±10%	5.5×4.0	3.15	5.0	K1	M1
RDER71H225K2□□H03□	X7R (EIA)	50Vdc	2.2μF±10%	5.5×4.0	3.15	2.5	P1	S1
RDER71H225K2□□H03□	X7R (EIA)	50Vdc	2.2μF±10%	5.5×4.0	3.15	5.0	K1	M1
RDER71H335K3□□H03□	X7R (EIA)	50Vdc	3.3μF±10%	5.5×5.0	4.0	2.5	P1	S1
RDER71H335K3□□H03□	X7R (EIA)	50Vdc	3.3μF±10%	5.5×5.0	4.0	5.0	K1	M1
RDEC71H475K2□□H03□	X7S (EIA)	50Vdc	4.7μF±10%	5.5×4.0	3.15	2.5	P1	S1
RDEC71H475K2□□H03□	X7S (EIA)	50Vdc	4.7μF±10%	5.5×4.0	3.15	5.0	K1	M1
RDEC71H106K3□□H03□	X7S (EIA)	50Vdc	10μF±10%	5.5×5.0	4.0	2.5	P1	S1
RDEC71H106K3□□H03□	X7S (EIA)	50Vdc	10μF±10%	5.5×5.0	4.0	5.0	K1	M1
RDEC71H226MW□□H03□	X7S (EIA)	50Vdc	22μF±20%	5.5×7.5	4.0	5.0	K1	M1
RDER72A221K0□□H03□	X7R (EIA)	100Vdc	220pF±10%	4.0×3.5	2.5	5.0	K1	M1
RDER72A221K0□□H03□	X7R (EIA)	100Vdc	220pF±10%	5.0×3.5	2.5	2.5	P1	S1
RDER72A331K0□□H03□	X7R (EIA)	100Vdc	330pF±10%	4.0×3.5	2.5	5.0	K1	M1
RDER72A331K0□□H03□	X7R (EIA)	100Vdc	330pF±10%	5.0×3.5	2.5	2.5	P1	S1
RDER72A471K0□□H03□	X7R (EIA)	100Vdc	470pF±10%	4.0×3.5	2.5	5.0	K1	M1
RDER72A471K0□□H03□	X7R (EIA)	100Vdc	470pF±10%	5.0×3.5	2.5	2.5	P1	S1
RDER72A681K0□□H03□	X7R (EIA)	100Vdc	680pF±10%	4.0×3.5	2.5	5.0	K1	M1
RDER72A681K0□□H03□	X7R (EIA)	100Vdc	680pF±10%	5.0×3.5	2.5	2.5	P1	S1
RDER72A102K0□□H03□	X7R (EIA)	100Vdc	1000pF±10%	4.0×3.5	2.5	5.0	K1	M1
RDER72A102K0□□H03□	X7R (EIA)	100Vdc	1000pF±10%	5.0×3.5	2.5	2.5	P1	S1
RDER72A152K0□□H03□	X7R (EIA)	100Vdc	1500pF±10%	4.0×3.5	2.5	5.0	K1	M1
RDER72A152K0□□H03□	X7R (EIA)	100Vdc	1500pF±10%	5.0×3.5	2.5	2.5	P1	S1
RDER72A222K0□□H03□	X7R (EIA)	100Vdc	2200pF±10%	4.0×3.5	2.5	5.0	K1	M1
RDER72A222K0□□H03□	X7R (EIA)	100Vdc	2200pF±10%	5.0×3.5	2.5	2.5	P1	S1
RDER72A332K0□□H03□	X7R (EIA)	100Vdc	3300pF±10%	4.0×3.5	2.5	5.0	K1	M1
RDER72A332K0□□H03□	X7R (EIA)	100Vdc	3300pF±10%	5.0×3.5	2.5	2.5	P1	S1
RDER72A472K0□□H03□	X7R (EIA)	100Vdc	4700pF±10%	4.0×3.5	2.5	5.0	K1	M1
RDER72A472K0□□H03□	X7R (EIA)	100Vdc	4700pF±10%	5.0×3.5	2.5	2.5	P1	S1
RDER72A682K0□□H03□	X7R (EIA)	100Vdc	6800pF±10%	4.0×3.5	2.5	5.0	K1	M1
RDER72A682K0□□H03□	X7R (EIA)	100Vdc	6800pF±10%	5.0×3.5	2.5	2.5	P1	S1
RDER72A103K0□□H03□	X7R (EIA)	100Vdc	10000pF±10%	4.0×3.5	2.5	5.0	K1	M1
RDER72A103K0□□H03□	X7R (EIA)	100Vdc	10000pF±10%	5.0×3.5	2.5	2.5	P1	S1
RDER72A153K0□□H03□	X7R (EIA)	100Vdc	15000pF±10%	4.0×3.5	2.5	5.0	K1	M1
RDER72A153K0□□H03□	X7R (EIA)	100Vdc	15000pF±10%	5.0×3.5	2.5	2.5	P1	S1
RDER72A223K0□□H03□	X7R (EIA)	100Vdc	22000pF±10%	4.0×3.5	2.5	5.0	K1	M1
RDER72A223K0□□H03□	X7R (EIA)	100Vdc	22000pF±10%	5.0×3.5	2.5	2.5	P1	S1
RDER72A333K1□□H03□	X7R (EIA)	100Vdc	33000pF±10%	4.5×3.5	3.15	5.0	K1	M1
RDER72A333K1□□H03□	X7R (EIA)	100Vdc	33000pF±10%	5.0×3.5	3.15	2.5	P1	S1
RDER72A473K1□□H03□	X7R (EIA)	100Vdc	47000pF±10%	4.5×3.5	3.15	5.0	K1	M1
RDER72A473K1□□H03□	X7R (EIA)	100Vdc	47000pF±10%	5.0×3.5	3.15	2.5	P1	S1
RDER72A683K1□□H03□	X7R (EIA)	100Vdc	68000pF±10%	4.5×3.5	3.15	5.0	K1	M1
RDER72A683K1□□H03□	X7R (EIA)	100Vdc	68000pF±10%	5.0×3.5	3.15	2.5	P1	S1
RDER72A104K1□□H03□	X7R (EIA)	100Vdc	0.1μF±10%	4.5×3.5	3.15	5.0	K1	M1
RDER72A104K1□□H03□	X7R (EIA)	100Vdc	0.1μF±10%	5.0×3.5	3.15	2.5	P1	S1
RDER72A154K2□□H03□	X7R (EIA)	100Vdc	0.15μF±10%	5.5×4.0	3.15	2.5	P1	S1
RDER72A154K2□□H03□	X7R (EIA)	100Vdc	0.15μF±10%	5.5×4.0	3.15	5.0	K1	M1
RDER72A224K1□□H03□	X7R (EIA)	100Vdc	0.22μF±10%	4.5×3.5	3.15	5.0	K1	M1
RDER72A224K1□□H03□	X7R (EIA)	100Vdc	0.22μF±10%	5.0×3.5	3.15	2.5	P1	S1

Continued on the following page. ↗

Continued from the preceding page.

Part Number	Temp. Char.	Rated Voltage	Capacitance	Dimensions LxW (mm)	Dimension T (mm)	Lead Space F (mm)	Lead Style Code Bulk	Lead Style Code Taping
RDER72A334K1□□H03□	X7R (EIA)	100Vdc	0.33μF±10%	4.5×3.5	3.15	5.0	K1	M1
RDER72A334K1□□H03□	X7R (EIA)	100Vdc	0.33μF±10%	5.0×3.5	3.15	2.5	P1	S1
RDER72A474K1□□H03□	X7R (EIA)	100Vdc	0.47μF±10%	4.5×3.5	3.15	5.0	K1	M1
RDER72A474K1□□H03□	X7R (EIA)	100Vdc	0.47μF±10%	5.0×3.5	3.15	2.5	P1	S1
RDER72A684K2□□H03□	X7R (EIA)	100Vdc	0.68μF±10%	5.5×4.0	3.15	2.5	P1	S1
RDER72A684K2□□H03□	X7R (EIA)	100Vdc	0.68μF±10%	5.5×4.0	3.15	5.0	K1	M1
RDER72A105K2□□H03□	X7R (EIA)	100Vdc	1.0μF±10%	5.5×4.0	3.15	2.5	P1	S1
RDER72A105K2□□H03□	X7R (EIA)	100Vdc	1.0μF±10%	5.5×4.0	3.15	5.0	K1	M1
RDEC72A155K3□□H03□	X7S (EIA)	100Vdc	1.5μF±10%	5.5×5.0	4.0	2.5	P1	S1
RDEC72A155K3□□H03□	X7S (EIA)	100Vdc	1.5μF±10%	5.5×5.0	4.0	5.0	K1	M1
RDEC72A225K3□□H03□	X7S (EIA)	100Vdc	2.2μF±10%	5.5×5.0	4.0	2.5	P1	S1
RDEC72A225K3□□H03□	X7S (EIA)	100Vdc	2.2μF±10%	5.5×5.0	4.0	5.0	K1	M1
RDEC72A475MW□□H03□	X7S (EIA)	100Vdc	4.7μF±20%	5.5×7.5	4.0	5.0	K1	M1
RDER72E102K1□□H03□	X7R (EIA)	250Vdc	1000pF±10%	4.5×3.5	3.15	5.0	K1	M1
RDER72E152K1□□H03□	X7R (EIA)	250Vdc	1500pF±10%	4.5×3.5	3.15	5.0	K1	M1
RDER72E222K1□□H03□	X7R (EIA)	250Vdc	2200pF±10%	4.5×3.5	3.15	5.0	K1	M1
RDER72E332K1□□H03□	X7R (EIA)	250Vdc	3300pF±10%	4.5×3.5	3.15	5.0	K1	M1
RDER72E472K1□□H03□	X7R (EIA)	250Vdc	4700pF±10%	4.5×3.5	3.15	5.0	K1	M1
RDER72E682K1□□H03□	X7R (EIA)	250Vdc	6800pF±10%	4.5×3.5	3.15	5.0	K1	M1
RDER72E103K1□□H03□	X7R (EIA)	250Vdc	10000pF±10%	4.5×3.5	3.15	5.0	K1	M1
RDER72E153K1□□H03□	X7R (EIA)	250Vdc	15000pF±10%	4.5×3.5	3.15	5.0	K1	M1
RDER72E223K1□□H03□	X7R (EIA)	250Vdc	22000pF±10%	4.5×3.5	3.15	5.0	K1	M1
RDER72E333K2□□H03□	X7R (EIA)	250Vdc	33000pF±10%	5.5×4.0	3.15	5.0	K1	M1
RDER72E473K2□□H03□	X7R (EIA)	250Vdc	47000pF±10%	5.5×4.0	3.15	5.0	K1	M1
RDER72E683K2□□H03□	X7R (EIA)	250Vdc	68000pF±10%	5.5×4.0	3.15	5.0	K1	M1
RDER72E104K2□□H03□	X7R (EIA)	250Vdc	0.10μF±10%	5.5×4.0	3.15	5.0	K1	M1
RDER72E154K3□□H03□	X7R (EIA)	250Vdc	0.15μF±10%	5.5×5.0	3.15	5.0	K1	M1
RDER72E224K3□□H03□	X7R (EIA)	250Vdc	0.22μF±10%	5.5×5.0	3.15	5.0	K1	M1
RDER72E334K4□□H03□	X7R (EIA)	250Vdc	0.33μF±10%	7.5×5.5	4.0	5.0	K1	M1
RDER72E474K4□□H03□	X7R (EIA)	250Vdc	0.47μF±10%	7.5×5.5	4.0	5.0	K1	M1
RDER72E684K5□□H03□	X7R (EIA)	250Vdc	0.68μF±10%	7.5×7.5	4.0	5.0	B1	E1
RDER72E105K5□□H03□	X7R (EIA)	250Vdc	1.0μF±10%	7.5×7.5	4.0	5.0	B1	E1
RDER72E225MU□□H03□	X7R (EIA)	250Vdc	2.2μF±20%	7.7×12.5	4.0	5.0	B1	E1
RDER72J102K2□□H03□	X7R (EIA)	630Vdc	1000pF±10%	5.5×4.0	3.15	5.0	K1	M1
RDER72J152K2□□H03□	X7R (EIA)	630Vdc	1500pF±10%	5.5×4.0	3.15	5.0	K1	M1
RDER72J222K2□□H03□	X7R (EIA)	630Vdc	2200pF±10%	5.5×4.0	3.15	5.0	K1	M1
RDER72J332K2□□H03□	X7R (EIA)	630Vdc	3300pF±10%	5.5×4.0	3.15	5.0	K1	M1
RDER72J472K2□□H03□	X7R (EIA)	630Vdc	4700pF±10%	5.5×4.0	3.15	5.0	K1	M1
RDER72J682K2□□H03□	X7R (EIA)	630Vdc	6800pF±10%	5.5×4.0	3.15	5.0	K1	M1
RDER72J103K2□□H03□	X7R (EIA)	630Vdc	10000pF±10%	5.5×4.0	3.15	5.0	K1	M1
RDER72J153K2□□H03□	X7R (EIA)	630Vdc	15000pF±10%	5.5×4.0	3.15	5.0	K1	M1
RDER72J223K2□□H03□	X7R (EIA)	630Vdc	22000pF±10%	5.5×4.0	3.15	5.0	K1	M1
RDER72J333K3□□H03□	X7R (EIA)	630Vdc	33000pF±10%	5.5×5.0	3.15	5.0	K1	M1
RDER72J473K3□□H03□	X7R (EIA)	630Vdc	47000pF±10%	5.5×5.0	3.15	5.0	K1	M1
RDER72J683K4□□H03□	X7R (EIA)	630Vdc	68000pF±10%	7.5×5.5	3.15	5.0	K1	M1
RDER72J104K4□□H03□	X7R (EIA)	630Vdc	0.10μF±10%	7.5×5.5	3.15	5.0	K1	M1
RDER72J154K5□□H03□	X7R (EIA)	630Vdc	0.15μF±10%	7.5×8.0	4.0	5.0	B1	E1
RDER72J224K5□□H03□	X7R (EIA)	630Vdc	0.22μF±10%	7.5×8.0	4.0	5.0	B1	E1
RDER72J474MU□□H03□	X7R (EIA)	630Vdc	0.47μF±20%	7.7×13.0	4.0	5.0	B1	E1
RDER73A471K2□□H03□	X7R (EIA)	1000Vdc	470pF±10%	5.5×4.0	3.15	5.0	K1	M1
RDER73A681K2□□H03□	X7R (EIA)	1000Vdc	680pF±10%	5.5×4.0	3.15	5.0	K1	M1
RDER73A102K2□□H03□	X7R (EIA)	1000Vdc	1000pF±10%	5.5×4.0	3.15	5.0	K1	M1
RDER73A152K2□□H03□	X7R (EIA)	1000Vdc	1500pF±10%	5.5×4.0	3.15	5.0	K1	M1
RDER73A222K2□□H03□	X7R (EIA)	1000Vdc	2200pF±10%	5.5×4.0	3.15	5.0	K1	M1
RDER73A332K2□□H03□	X7R (EIA)	1000Vdc	3300pF±10%	5.5×4.0	3.15	5.0	K1	M1
RDER73A472K2□□H03□	X7R (EIA)	1000Vdc	4700pF±10%	5.5×4.0	3.15	5.0	K1	M1
RDER73A682K2□□H03□	X7R (EIA)	1000Vdc	6800pF±10%	5.5×4.0	3.15	5.0	K1	M1

Continued on the following page. ↗

Continued from the preceding page.

Part Number	Temp. Char.	Rated Voltage	Capacitance	Dimensions LxW (mm)	Dimension T (mm)	Lead Space F (mm)	Lead Style Code Bulk	Lead Style Code Taping
RDER73A103K2□□H03□	X7R (EIA)	1000Vdc	10000pF±10%	5.5×4.0	3.15	5.0	K1	M1
RDER73A153K3□□H03□	X7R (EIA)	1000Vdc	15000pF±10%	5.5×5.0	4.0	5.0	K1	M1
RDER73A223K3□□H03□	X7R (EIA)	1000Vdc	22000pF±10%	5.5×5.0	4.0	5.0	K1	M1
RDER73A333K4□□H03□	X7R (EIA)	1000Vdc	33000pF±10%	7.5×5.5	4.0	5.0	K1	M1
RDER73A473K4□□H03□	X7R (EIA)	1000Vdc	47000pF±10%	7.5×5.5	4.0	5.0	K1	M1
RDER73A683K5□□H03□	X7R (EIA)	1000Vdc	68000pF±10%	7.5×8.0	4.0	5.0	B1	E1
RDER73A104K5□□H03□	X7R (EIA)	1000Vdc	0.10μF±10%	7.5×8.0	4.0	5.0	B1	E1
RDER73A224MU□□H03□	X7R (EIA)	1000Vdc	0.22μF±20%	7.7×13.0	4.0	5.0	B1	E1

Two blank columns are filled with the lead style code. Please refer to the 3 columns on the right for the appropriate code.
 The last blank column is filled with the packaging code. (B: bulk, A: ammo pack)

3

High Dielectric Constant Type, F/Y5V Characteristics

Part Number	Temp. Char.	Rated Voltage	Capacitance	Dimensions LxW (mm)	Dimension T (mm)	Lead Space F (mm)	Lead Style Code Bulk	Lead Style Code Taping
RDEF11H103Z0□□H01□	F (JIS)	50Vdc	10000pF+80/-20%	4.0×3.5	2.5	5.0	K1	M1
RDEF11H103Z0□□H01□	F (JIS)	50Vdc	10000pF+80/-20%	5.0×3.5	2.5	2.5	P1	S1
RDEF51H103Z0□□H03□	Y5V (EIA)	50Vdc	10000pF+80/-20%	4.0×3.5	2.5	5.0	K1	M1
RDEF51H103Z0□□H03□	Y5V (EIA)	50Vdc	10000pF+80/-20%	5.0×3.5	2.5	2.5	P1	S1
RDEF11H223Z0□□H01□	F (JIS)	50Vdc	22000pF+80/-20%	4.0×3.5	2.5	5.0	K1	M1
RDEF11H223Z0□□H01□	F (JIS)	50Vdc	22000pF+80/-20%	5.0×3.5	2.5	2.5	P1	S1
RDEF51H223Z0□□H03□	Y5V (EIA)	50Vdc	22000pF+80/-20%	4.0×3.5	2.5	5.0	K1	M1
RDEF51H223Z0□□H03□	Y5V (EIA)	50Vdc	22000pF+80/-20%	5.0×3.5	2.5	2.5	P1	S1
RDEF11H473Z0□□H01□	F (JIS)	50Vdc	47000pF+80/-20%	4.0×3.5	2.5	5.0	K1	M1
RDEF11H473Z0□□H01□	F (JIS)	50Vdc	47000pF+80/-20%	5.0×3.5	2.5	2.5	P1	S1
RDEF51H473Z0□□H03□	Y5V (EIA)	50Vdc	47000pF+80/-20%	4.0×3.5	2.5	5.0	K1	M1
RDEF51H473Z0□□H03□	Y5V (EIA)	50Vdc	47000pF+80/-20%	5.0×3.5	2.5	2.5	P1	S1
RDEF11H104Z0□□H01□	F (JIS)	50Vdc	0.1μF+80/-20%	4.0×3.5	2.5	5.0	K1	M1
RDEF11H104Z0□□H01□	F (JIS)	50Vdc	0.1μF+80/-20%	5.0×3.5	2.5	2.5	P1	S1
RDEF51H104Z0□□H03□	Y5V (EIA)	50Vdc	0.1μF+80/-20%	4.0×3.5	2.5	5.0	K1	M1
RDEF51H104Z0□□H03□	Y5V (EIA)	50Vdc	0.1μF+80/-20%	5.0×3.5	2.5	2.5	P1	S1

Two blank columns are filled with the lead style code. Please refer to the 3 columns on the right for the appropriate code.
 The last blank column is filled with the packaging code. (B: bulk, A: ammo pack)

Specifications and Test Methods

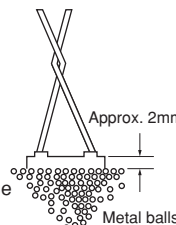
No.	Item	Specifications		Test Method																					
		Temperature Compensating Type	High Dielectric Constant Type																						
1	Operating Temperature Range	-55 to +125°C	Char. X7R, X7S: -55 to +125°C Char. F: -25 to +85°C Char. Y5V: -30 to +85°C	-																					
2	Appearance	No defects or abnormalities		Visual inspection																					
3	Dimension and Marking	See previous pages		Visual inspection, Vernier Caliper																					
4	Dielectric Strength	Between Terminals	No defects or abnormalities	The capacitors should not be damaged when test voltages of Table are applied between the terminals for 1 to 5 sec. (Charge/Discharge current ≤ 50mA) <table border="1" style="margin-top: 10px; width: 100%;"> <thead> <tr> <th></th> <th>Rated Voltage</th> <th>Test Voltage</th> </tr> </thead> <tbody> <tr> <td rowspan="3">Temperature Compensating Type</td> <td>DC50V, DC100V</td> <td>300% of the rated voltage</td> </tr> <tr> <td>DC250V</td> <td>200% of the rated voltage</td> </tr> <tr> <td>DC630V</td> <td>150% of the rated voltage</td> </tr> <tr> <td rowspan="4">High Dielectric Constant Type</td> <td>DC1kV</td> <td>130% of the rated voltage</td> </tr> <tr> <td>DC25V, DC50V</td> <td>250% of the rated voltage</td> </tr> <tr> <td>DC100V, DC250V</td> <td>200% of the rated voltage</td> </tr> <tr> <td>DC630V</td> <td>150% of the rated voltage</td> </tr> <tr> <td>DC1kV</td> <td>120% of the rated voltage</td> </tr> </tbody> </table>		Rated Voltage	Test Voltage	Temperature Compensating Type	DC50V, DC100V	300% of the rated voltage	DC250V	200% of the rated voltage	DC630V	150% of the rated voltage	High Dielectric Constant Type	DC1kV	130% of the rated voltage	DC25V, DC50V	250% of the rated voltage	DC100V, DC250V	200% of the rated voltage	DC630V	150% of the rated voltage	DC1kV	120% of the rated voltage
			Rated Voltage		Test Voltage																				
Temperature Compensating Type	DC50V, DC100V	300% of the rated voltage																							
	DC250V	200% of the rated voltage																							
	DC630V	150% of the rated voltage																							
High Dielectric Constant Type	DC1kV	130% of the rated voltage																							
	DC25V, DC50V	250% of the rated voltage																							
	DC100V, DC250V	200% of the rated voltage																							
	DC630V	150% of the rated voltage																							
DC1kV	120% of the rated voltage																								
Body Insulation	No defects or abnormalities	The capacitor is placed in a container with metal balls of 1mm diameter so that each terminal, short-circuited, is kept approximately 2mm from the balls as shown in the figure, for 1 to 5 sec. between capacitor terminals and metal balls. (Charge/Discharge current ≤ 50mA) <div style="text-align: right; margin-top: 10px;">  <p style="font-size: small;">Approx. 2mm Metal balls</p> </div> <table border="1" style="margin-top: 10px; width: 100%;"> <thead> <tr> <th>Rated Voltage</th> <th>Test Voltage</th> </tr> </thead> <tbody> <tr> <td>DC25V, DC50V</td> <td>250% of the rated voltage</td> </tr> <tr> <td>DC100V, DC250V</td> <td>200% of the rated voltage</td> </tr> <tr> <td>DC630V, DC1kV</td> <td>DC1300V</td> </tr> </tbody> </table>	Rated Voltage	Test Voltage	DC25V, DC50V	250% of the rated voltage	DC100V, DC250V	200% of the rated voltage	DC630V, DC1kV	DC1300V															
Rated Voltage	Test Voltage																								
DC25V, DC50V	250% of the rated voltage																								
DC100V, DC250V	200% of the rated voltage																								
DC630V, DC1kV	DC1300V																								
5	Insulation Resistance	Between Terminals	Rated Voltage: DC25V, DC50V, DC100V 10,000MΩ min. or 500MΩ • μF min. whichever is smaller Rated Voltage: DC250V, DC630V 10,000MΩ min. or 100MΩ • μF min. whichever is smaller	The insulation resistance should be measured with a DC voltage not exceeding the rated voltage (DC500±50V in case of rated voltage: DC630V, DC1kV) at normal temperature and humidity and within 2 min. of charging. (Charge/Discharge current ≤ 50mA)																					
6	Capacitance	Within the specified tolerance		The capacitance, Q/D.F. should be measured at 25°C at the frequency and voltage shown in the table.																					
7	Q/Dissipation Factor (D.F.)	30pF min.: Q ≥ 1,000 30pF max.: Q ≥ 400+20C C: Nominal capacitance (pF)	Char. X7R: 0.025 max. Char. F, Y5V: 0.05 max. Char. X7S: 0.125 max.	Temperature Compensating Type <table border="1" style="margin-top: 10px; width: 100%;"> <thead> <tr> <th rowspan="2">Item \ Capacitance</th> <th>C ≤ 1000pF</th> <th>C > 1000pF</th> </tr> </thead> <tbody> <tr> <td>Frequency</td> <td>1 ± 0.1MHz</td> <td>1 ± 0.1kHz</td> </tr> <tr> <td>Voltage</td> <td>AC0.5 to 5V (r.m.s.)</td> <td>AC1 ± 0.2V (r.m.s.)</td> </tr> </tbody> </table>	Item \ Capacitance	C ≤ 1000pF	C > 1000pF	Frequency	1 ± 0.1MHz	1 ± 0.1kHz	Voltage	AC0.5 to 5V (r.m.s.)	AC1 ± 0.2V (r.m.s.)												
				Item \ Capacitance		C ≤ 1000pF	C > 1000pF																		
Frequency	1 ± 0.1MHz	1 ± 0.1kHz																							
Voltage	AC0.5 to 5V (r.m.s.)	AC1 ± 0.2V (r.m.s.)																							
High Dielectric Constant Type <table border="1" style="margin-top: 10px; width: 100%;"> <thead> <tr> <th rowspan="2">Item \ Capacitance</th> <th>C ≤ 10μF</th> <th>C > 10μF</th> </tr> </thead> <tbody> <tr> <td>Frequency</td> <td>1 ± 0.1kHz</td> <td>120 ± 24Hz</td> </tr> <tr> <td>Voltage</td> <td>AC1 ± 0.2V (r.m.s.)</td> <td>AC0.5 ± 0.1V (r.m.s.)</td> </tr> </tbody> </table>	Item \ Capacitance	C ≤ 10μF	C > 10μF	Frequency	1 ± 0.1kHz	120 ± 24Hz	Voltage	AC1 ± 0.2V (r.m.s.)	AC0.5 ± 0.1V (r.m.s.)																
Item \ Capacitance		C ≤ 10μF	C > 10μF																						
	Frequency	1 ± 0.1kHz	120 ± 24Hz																						
Voltage	AC1 ± 0.2V (r.m.s.)	AC0.5 ± 0.1V (r.m.s.)																							

Continued on the following page.

3

Specifications and Test Methods

Continued from the preceding page.

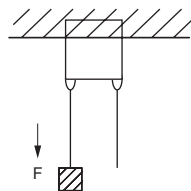
No.	Item		Specifications		Test Method												
			Temperature Compensating Type	High Dielectric Constant Type													
8	Capacitance Temperature Characteristics	Capacitance Change	Within the specified tolerance (Table A on last column)	Within the specified tolerance (Table B on last column)	The capacitance change should be measured after 5 min. at each specified temperature stage. (1) Temperature Compensating Type The temperature coefficient is determined using the capacitance measured in step 3 as a reference. When cycling the temperature sequentially from step 1 through 5 (-55 to +125°C) the capacitance should be within the specified tolerance for the temperature coefficient and capacitance change as shown in Table A. The capacitance drift is calculated by dividing the differences between the maximum and minimum measured values in step 1, 3 and 5 by the cap. value in step 3. <table border="1" style="margin: 10px auto;"> <thead> <tr> <th>Step</th> <th>Temperature (°C)</th> </tr> </thead> <tbody> <tr> <td>1</td> <td>25±2</td> </tr> <tr> <td>2</td> <td>-55±3</td> </tr> <tr> <td>3</td> <td>25±2</td> </tr> <tr> <td>4</td> <td>125±3</td> </tr> <tr> <td>5</td> <td>25±2</td> </tr> </tbody> </table> (2) High Dielectric Constant Type The ranges of capacitance change compared with the 25°C (Char. F: 20°C) value over the temperature ranges as shown in Table B should be within the specified ranges. • Pretreatment (for high dielectric constant type) Perform a heat treatment at 150+0/-10°C for 1 hr., and then let sit at room temperature for 24±2 hrs.	Step	Temperature (°C)	1	25±2	2	-55±3	3	25±2	4	125±3	5	25±2
		Step	Temperature (°C)														
		1	25±2														
2	-55±3																
3	25±2																
4	125±3																
5	25±2																
Temperature Coefficient	Within the specified tolerance (Table A on last column)																
Capacitance Drift	Within ±0.2% or ±0.05pF, whichever is larger																
9	Terminal Strength	Tensile Strength	Termination not to be broken or loosened		As in the figure, fix the capacitor body, apply the force gradually to each lead in the radial direction of the capacitor until reaching 10N and then keep the force applied for 10±1 sec. 												
		Bending Strength	Termination not to be broken or loosened		Each lead wire should be subjected to a force of 2.5N and then bent 90° at the point of egress in one direction. Each wire is then returned to the original position and bent 90° in the opposite direction at the rate of one bend per 2 to 3 sec.												
10	Vibration Resistance	Appearance	No defects or abnormalities		The capacitor is soldered securely to a supporting terminal and a 10 to 55Hz vibration of 1.5mm peak-peak amplitude is applied for 6 hrs. total, 2 hrs. in each mutually perpendicular direction. Allow 1 min. to cycle the frequency from 10Hz to 55Hz and the converse.												
		Capacitance	Within the specified tolerance														
		Q/D.F.	30pF min.: Q≥1,000 30pF max.: Q≥400+20C C: Nominal capacitance (pF)	Char. X7R: 0.025 max. Char. F, Y5V: 0.05 max. Char. X7S: 0.125 max.													
11	Solderability of Leads		Lead wire should be soldered with uniform coating on the axial direction over 3/4 of the circumferential direction.		The terminal of a capacitor is dipped into a 25% ethanol (JIS-K-8101) solution of rosin (JIS-K-5902) and then into molten solder for 2±0.5 sec. In both cases the depth of dipping is up to about 1.5mm to 2mm from the terminal body. Temp. of solder: 245±5°C Lead Free Solder (Sn-3.0Ag-0.5Cu) 235±5°C H60A or H63A Eutectic Solder												
12	Resistance to Soldering Heat	Appearance	No defects or abnormalities		The lead wire is immersed in the melted solder 1.5mm to 2mm from the main body at 350±10°C for 3.5±0.5 sec. The specified items are measured after 24±2 hrs. • Pretreatment (for high dielectric constant type) Perform a heat treatment at 150+0/-10°C for 1 hr., and then let sit at room temperature for 24±2 hrs.												
		Capacitance Change	Within ±2.5% or ±0.25pF (whichever is larger)	Char. X7R, X7S: Within ±10% Char. F, Y5V: Within ±20%													
		Dielectric Strength (Between Terminals)	No defects														

Continued on the following page. 

Specifications and Test Methods

Continued from the preceding page.

No.	Item	Specifications		Test Method																
		Temperature Compensating Type	High Dielectric Constant Type																	
13	Temperature Cycle	Appearance	No defects or abnormalities		The capacitor should be subjected to 5 temperature cycles. Remove and set for 24±2 hrs. at room temperature, then measure. <table border="1" style="margin-top: 10px; width: 100%; border-collapse: collapse;"> <thead> <tr> <th>Step</th> <th>Temperature (°C)</th> <th>Time (min)</th> </tr> </thead> <tbody> <tr> <td>1</td> <td>Min. Operating Temp. ±3</td> <td>30±3</td> </tr> <tr> <td>2</td> <td>Room Temp.</td> <td>3 max.</td> </tr> <tr> <td>3</td> <td>Max. Operating Temp. ±3</td> <td>30±3</td> </tr> <tr> <td>4</td> <td>Room Temp.</td> <td>3 max.</td> </tr> </tbody> </table> <ul style="list-style-type: none"> • Pretreatment (for high dielectric constant type) Perform a heat treatment at 150+0/-10°C for 1 hr., and then let sit at room temperature for 24±2 hrs. 	Step	Temperature (°C)	Time (min)	1	Min. Operating Temp. ±3	30±3	2	Room Temp.	3 max.	3	Max. Operating Temp. ±3	30±3	4	Room Temp.	3 max.
		Step	Temperature (°C)	Time (min)																
		1	Min. Operating Temp. ±3	30±3																
		2	Room Temp.	3 max.																
		3	Max. Operating Temp. ±3	30±3																
4	Room Temp.	3 max.																		
Capacitance Change	Within ±5% or ±0.5pF (whichever is larger)	Char. X7R, X7S: Within ±12.5% Char. F, Y5V: Within ±30%																		
Q/D.F.	30pF min.: Q≥350 10pF to 30pF: Q≥275+5C/2 10pF max.: Q≥200+10C C: Nominal capacitance (pF)	Char. X7R: 0.05 max. Char. F, Y5V: 0.075 max. Char. X7S: 0.2 max.																		
Insulation Resistance	Rated Voltage: DC25V, DC50V, DC100V 1,000MΩ, 50MΩ • μF min. (whichever is smaller) Rated Voltage: DC250V, DC630V 1,000MΩ, 10MΩ • μF min. (whichever is smaller)																			
Dielectric Strength (Between Terminals)	No defects or abnormalities																			
14	Humidity (Steady State)	Appearance	No defects or abnormalities		Set the capacitor at 40±2°C and relative humidity of 90 to 95% for 500±24 hrs. Remove and set for 24±2 hrs. at room temperature, then measure. <ul style="list-style-type: none"> • Pretreatment (for high dielectric constant type) Perform a heat treatment at 150+0/-10°C for 1 hr., and then let sit at room temperature for 24±2 hrs. 															
		Capacitance Change	Within ±5% or ±0.5pF (whichever is larger)	Char. X7R, X7S: Within ±15% Char. F, Y5V: Within ±30%																
		Q/D.F.	30pF min.: Q≥350 10pF to 30pF: Q≥275+5C/2 10pF max.: Q≥200+10C C: Nominal capacitance (pF)	Char. X7R: 0.05 max. Char. F, Y5V: 0.075 max. Char. X7S: 0.2 max.																
		Insulation Resistance	Rated Voltage: DC25V, DC50V, DC100V 1,000MΩ, 50MΩ • μF min. (whichever is smaller) Rated Voltage: DC250V, DC630V 1,000MΩ, 10MΩ • μF min. (whichever is smaller)																	
15	Humidity Load	Appearance	No defects or abnormalities		Apply the rated voltage for 500±24 hrs. at 40±2°C and in 90 to 95% humidity. Remove and set for 24±2 hrs. at room temperature, then measure. (Charge/Discharge current ≤50mA) <ul style="list-style-type: none"> • Pretreatment (for high dielectric constant type) Perform a heat treatment at 150+0/-10°C for 1 hr., and then let sit at room temperature for 24±2 hrs. 															
		Capacitance Change	Within ±7.5% or ±0.75pF (whichever is larger)	Char. X7R, X7S: Within ±15% Char. F, Y5V: Within ±30%																
		Q/D.F.	30pF min.: Q≥200 30pF max.: Q≥100+10C/3 C: Nominal capacitance (pF)	Char. X7R: 0.05 max. Char. F, Y5V: 0.075 max. Char. X7S: 0.2 max.																
		Insulation Resistance	Rated Voltage: DC25V, DC50V, DC100V 500MΩ or 25MΩ • μF min. (whichever is smaller) Rated Voltage: DC250V, DC630V 1,000MΩ or 10MΩ • μF min. (whichever is smaller)																	
16	High Temperature Load	Appearance	No defects or abnormalities		Apply voltage in Table for 1000±48 hrs. at the maximum operating temperature±3°C. Remove and set for 24±2 hrs. at room temperature, then measure. (Charge/Discharge current ≤50mA) <table border="1" style="margin-top: 10px; width: 100%; border-collapse: collapse;"> <thead> <tr> <th></th> <th>Rated Voltage</th> <th>Test Voltage</th> </tr> </thead> <tbody> <tr> <td rowspan="2">Temperature Compensating Type</td> <td>DC50V, DC100V, DC250V</td> <td>150% of the rated voltage</td> </tr> <tr> <td>DC630V, DC1kV</td> <td>120% of the rated voltage</td> </tr> <tr> <td rowspan="3">High Dielectric Constant Type</td> <td>DC25V, DC50V, DC100V, DC250V</td> <td>150% of the rated voltage</td> </tr> <tr> <td>DC630V</td> <td>120% of the rated voltage</td> </tr> <tr> <td>DC1kV</td> <td>110% of the rated voltage</td> </tr> </tbody> </table> <ul style="list-style-type: none"> • Pretreatment (for high dielectric constant type) Apply test voltage for 1 hr., at test temperature. Remove and set for 24±2 hrs. at room temperature. 		Rated Voltage	Test Voltage	Temperature Compensating Type	DC50V, DC100V, DC250V	150% of the rated voltage	DC630V, DC1kV	120% of the rated voltage	High Dielectric Constant Type	DC25V, DC50V, DC100V, DC250V	150% of the rated voltage	DC630V	120% of the rated voltage	DC1kV	110% of the rated voltage
			Rated Voltage	Test Voltage																
		Temperature Compensating Type	DC50V, DC100V, DC250V	150% of the rated voltage																
			DC630V, DC1kV	120% of the rated voltage																
High Dielectric Constant Type	DC25V, DC50V, DC100V, DC250V	150% of the rated voltage																		
	DC630V	120% of the rated voltage																		
	DC1kV	110% of the rated voltage																		
Capacitance Change	Within ±3% or ±0.3pF (whichever is larger)	Char. X7R, X7S: Within ±15% (Rated Voltage: DC630V or less) Within ±20% (Rated Voltage: DC1kV) Char. F, Y5V: Within ±30%																		
Q/D.F.	30pF min.: Q≥350 10pF to 30pF: Q≥275+5C/2 10pF max.: Q≥200+10C C: Nominal capacitance (pF)	Char. X7R: 0.05 max. Char. F, Y5V: 0.075 max. Char. X7S: 0.2 max.																		
Insulation Resistance	Rated Voltage: DC25V, DC50V, DC100V 1,000MΩ, 50MΩ • μF min. (whichever is smaller) Rated Voltage: DC250V, DC630V 1,000MΩ, 10MΩ • μF min. (whichever is smaller)																			
17	Solvent Resistance	Appearance	No defects or abnormalities		The capacitor should be fully immersed, unagitated, in reagent at 20 to 25°C for 30±5 sec. and then removed gently. Marking on the surface of the capacitor should immediately be visually examined. Reagent: <ul style="list-style-type: none"> • Isopropyl alcohol 															
		Marking	Legible																	

Table A

Char.	Nominal Values (ppm/°C) *1	Capacitance Change from 25°C (%)					
		-55°C		-30°C		-10°C	
		Max.	Min.	Max.	Min.	Max.	Min.
C0G	0±30	0.58	-0.24	0.40	-0.17	0.25	-0.11
U2J	-750±120	8.78	5.04	6.04	3.47	3.84	2.21

*1: Nominal values denote the temperature coefficient within a range of 25 to 125°C

Table B

Char.	Temp. Range	Reference Temp.	Cap. Change Rate
X7R	-55 to +125°C	25°C	Within ±15%
X7S			Within ±22%
Y5V	-30 to + 85°C	20°C	Within ±33%
F	-25 to + 85°C		Within ±38%

Radial Lead Type Monolithic Ceramic Capacitors



RDE Series Large Capacitance and High Allowable Ripple Current (For General Use Only) (DC250V-DC630V)

■ Features

- Higher capacitance with DC-Bias; approximately 40% higher than X7R under loaded rated voltage.
- Meet LF (Lead Free) and HF (Halogen Free)
- Allowable higher ripple current
- Reduces acoustic noise
 Approximately 15dB reduction in comparison to leaded X7R characteristics parts.
 Approximately 30dB reduction in comparison to SMD X7R characteristics part because the contact area is smaller than a SMD.

■ Applications

- DC smoothing capacitor for LED bulb
- PFC capacitor for general use SMPS
- Replace Al-E capacitor for long-life equipment

■ Dimensions

Dimensions and Lead Style Code	DC Rated Voltage	Dimensions (mm)					
		L	W	W1	T	F	d
2K1/2M1	250V/450V/630V	5.5	4.0	6.0	See the individual product specification	5.0	0.5
3K1/3M1	250V/450V/630V	5.5	5.0	7.5		5.0	0.5
4K1/4M1	250V/450V/630V	7.5	5.5	8.0		5.0	0.5
5B1/5E1	250V/450V/630V	7.5	7.5*	-		5.0	0.5
UB1/UE1	250V/450V/630V	7.7	12.5*	-		5.0	0.5

*DC630V: W+0.5mm

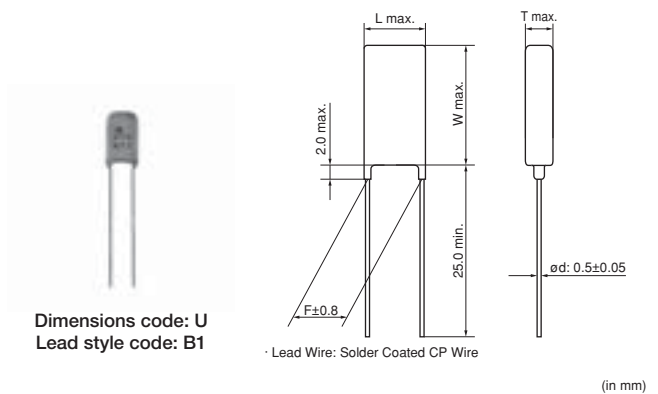
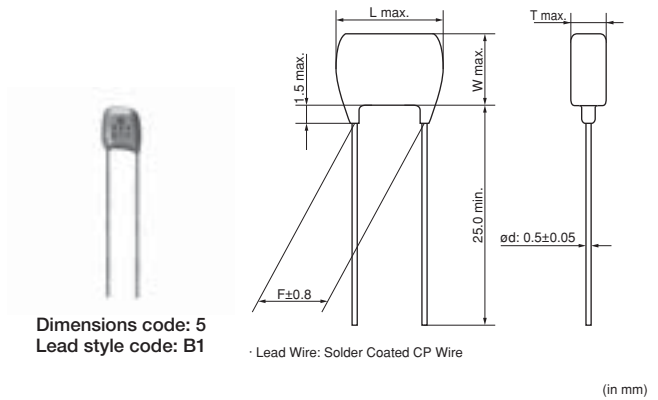
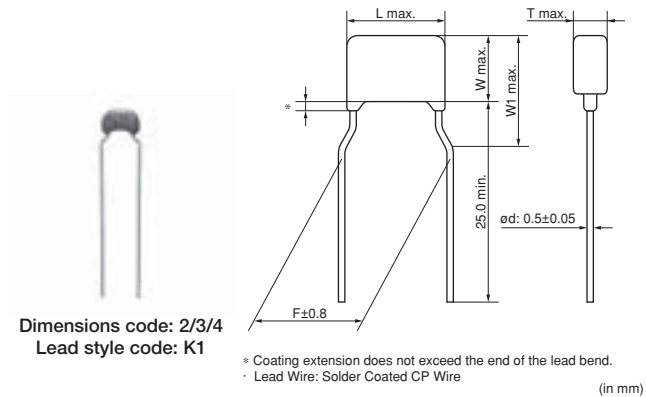

■ Marking

Dimensions Code	Rated Voltage	DC250V	DC450V	DC630V
	Temp. Char.	X7T		
2				
3, 8				
5, U				
Temperature Characteristics		Marked with code (X7T char.: 7)		
Nominal Capacitance		Marked with 3 figures		
Capacitance Tolerance		Marked with code		
Rated Voltage		Marked with code (DC250V: 4, DC450V: 9, DC630V: 7)		
Manufacturer's Identification		Marked with		

4

High Dielectric Constant Type, X7T Characteristics

Part Number	Temp. Char.	Rated Voltage	Capacitance	Dimensions LxW (mm)	Dimension T (mm)	Lead Space F (mm)	Lead Style Code Bulk	Lead Style Code Taping
RDED72E333K2□□H03□	X7T (EIA)	250Vdc	33000pF±10%	5.5x4.0	3.15	5.0	K1	M1
RDED72E473K2□□H03□	X7T (EIA)	250Vdc	47000pF±10%	5.5x4.0	3.15	5.0	K1	M1
RDED72E683K2□□H03□	X7T (EIA)	250Vdc	68000pF±10%	5.5x4.0	3.15	5.0	K1	M1
RDED72E104K3□□H03□	X7T (EIA)	250Vdc	0.10µF±10%	5.5x5.0	4.0	5.0	K1	M1
RDED72E154K3□□H03□	X7T (EIA)	250Vdc	0.15µF±10%	5.5x5.0	4.0	5.0	K1	M1
RDED72E224K4□□H03□	X7T (EIA)	250Vdc	0.22µF±10%	7.5x5.5	4.0	5.0	K1	M1
RDED72E334K4□□H03□	X7T (EIA)	250Vdc	0.33µF±10%	7.5x5.5	4.0	5.0	K1	M1
RDED72E474K5□□H03□	X7T (EIA)	250Vdc	0.47µF±10%	7.5x7.5	4.5	5.0	B1	E1
RDED72E684K5□□H03□	X7T (EIA)	250Vdc	0.68µF±10%	7.5x7.5	4.5	5.0	B1	E1
RDED72E105K5□□H03□	X7T (EIA)	250Vdc	1.0µF±10%	7.5x7.5	4.5	5.0	B1	E1
RDED72E225MU□□H03□	X7T (EIA)	250Vdc	2.2µF±20%	7.7x12.5	4.5	5.0	B1	E1
RDED72W103K2□□H03□	X7T (EIA)	450Vdc	10000pF±10%	5.5x4.0	3.15	5.0	K1	M1
RDED72W153K2□□H03□	X7T (EIA)	450Vdc	15000pF±10%	5.5x4.0	3.15	5.0	K1	M1
RDED72W223K2□□H03□	X7T (EIA)	450Vdc	22000pF±10%	5.5x4.0	3.15	5.0	K1	M1
RDED72W333K2□□H03□	X7T (EIA)	450Vdc	33000pF±10%	5.5x4.0	3.15	5.0	K1	M1
RDED72W473K2□□H03□	X7T (EIA)	450Vdc	47000pF±10%	5.5x4.0	3.15	5.0	K1	M1
RDED72W683K3□□H03□	X7T (EIA)	450Vdc	68000pF±10%	5.5x5.0	4.0	5.0	K1	M1
RDED72W104K3□□H03□	X7T (EIA)	450Vdc	0.10µF±10%	5.5x5.0	4.0	5.0	K1	M1
RDED72W154K4□□H03□	X7T (EIA)	450Vdc	0.15µF±10%	7.5x5.5	4.0	5.0	K1	M1
RDED72W224K5□□H03□	X7T (EIA)	450Vdc	0.22µF±10%	7.5x7.5	4.5	5.0	B1	E1
RDED72W334K5□□H03□	X7T (EIA)	450Vdc	0.33µF±10%	7.5x7.5	4.5	5.0	B1	E1
RDED72W474K5□□H03□	X7T (EIA)	450Vdc	0.47µF±10%	7.5x7.5	4.5	5.0	B1	E1
RDED72W564K5□□H03□	X7T (EIA)	450Vdc	0.56µF±10%	7.5x7.5	4.5	5.0	B1	E1
RDED72W105MU□□H03□	X7T (EIA)	450Vdc	1.0µF±20%	7.7x12.5	4.5	5.0	B1	E1
RDED72W125MU□□H03□	X7T (EIA)	450Vdc	1.2µF±20%	7.7x12.5	4.5	5.0	B1	E1
RDED72J103K2□□H03□	X7T (EIA)	630Vdc	10000pF±10%	5.5x4.0	3.15	5.0	K1	M1
RDED72J153K2□□H03□	X7T (EIA)	630Vdc	15000pF±10%	5.5x4.0	3.15	5.0	K1	M1
RDED72J223K3□□H03□	X7T (EIA)	630Vdc	22000pF±10%	5.5x5.0	4.0	5.0	K1	M1
RDED72J333K3□□H03□	X7T (EIA)	630Vdc	33000pF±10%	5.5x5.0	4.0	5.0	K1	M1
RDED72J473K3□□H03□	X7T (EIA)	630Vdc	47000pF±10%	5.5x5.0	4.0	5.0	K1	M1
RDED72J683K4□□H03□	X7T (EIA)	630Vdc	68000pF±10%	7.5x5.5	4.0	5.0	K1	M1
RDED72J104K5□□H03□	X7T (EIA)	630Vdc	0.10µF±10%	7.5x8.0	4.5	5.0	B1	E1
RDED72J154K5□□H03□	X7T (EIA)	630Vdc	0.15µF±10%	7.5x8.0	4.5	5.0	B1	E1

Continued on the following page.

Continued from the preceding page.

Part Number	Temp. Char.	Rated Voltage	Capacitance	Dimensions LxW (mm)	Dimension T (mm)	Lead Space F (mm)	Lead Style Code Bulk	Lead Style Code Taping
RDED72J224K5□□H03□	X7T (EIA)	630Vdc	0.22μF±10%	7.5×8.0	4.5	5.0	B1	E1
RDED72J274K5□□H03□	X7T (EIA)	630Vdc	0.27μF±10%	7.5×8.0	4.5	5.0	B1	E1
RDED72J474MU□□H03□	X7T (EIA)	630Vdc	0.47μF±20%	7.7×13.0	4.5	5.0	B1	E1
RDED72J564MU□□H03□	X7T (EIA)	630Vdc	0.56μF±20%	7.7×13.0	4.5	5.0	B1	E1

Two blank columns are filled with the lead style code. Please refer to the 3 columns on the right for the appropriate code.
 The last blank column is filled with the packaging code. (B: bulk, A: ammo pack)

Specifications and Test Methods

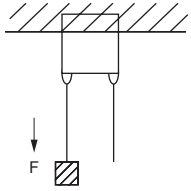
No.	Item		Specifications	Test Method												
1	Operating Temperature Range		-55 to +125°C	-												
2	Appearance		No defects or abnormalities	Visual inspection												
3	Dimension and Marking		See previous pages	Visual inspection, Vernier Caliper												
4	Dielectric Strength	Between Terminals	No defects or abnormalities	The capacitor should not be damaged when voltage in Table is applied between the terminations for 1 to 5 sec. (Charge/Discharge current \leq 50mA) <table border="1" style="margin-left: auto; margin-right: auto;"> <thead> <tr> <th>Rated Voltage</th> <th>Test Voltage</th> </tr> </thead> <tbody> <tr> <td>DC250V</td> <td>200% of the rated voltage</td> </tr> <tr> <td>DC450V</td> <td>150% of the rated voltage</td> </tr> <tr> <td>DC630V</td> <td>120% of the rated voltage</td> </tr> </tbody> </table>	Rated Voltage	Test Voltage	DC250V	200% of the rated voltage	DC450V	150% of the rated voltage	DC630V	120% of the rated voltage				
	Rated Voltage	Test Voltage														
DC250V	200% of the rated voltage															
DC450V	150% of the rated voltage															
DC630V	120% of the rated voltage															
		Body Insulation	No defects or abnormalities													
5	Insulation Resistance	Between Terminals	More than 10,000M Ω or 100M Ω · μ F, Whichever is smaller	The insulation resistance should be measured with DC500 \pm 50V (DC250 \pm 25V in case of rated voltage: DC250V, DC450V) at normal temperature and humidity and within 2 min. of charging. (Charge/Discharge current \leq 50mA)												
6	Capacitance		Within the specified tolerance	The capacitance/D.F. should be measured at the frequency of 1 \pm 0.1kHz and a voltage of AC1 \pm 0.2V(r.m.s.).												
7	Dissipation Factor (D.F.)		0.01 max.													
8	Capacitance Temperature Characteristics		Within +22/-33%	The capacitance change should be measured after 5 min. at each specified temperature stage. <table border="1" style="margin-left: auto; margin-right: auto;"> <thead> <tr> <th>Step</th> <th>Temperature (°C)</th> </tr> </thead> <tbody> <tr> <td>1</td> <td>25\pm2</td> </tr> <tr> <td>2</td> <td>-55\pm3</td> </tr> <tr> <td>3</td> <td>25\pm2</td> </tr> <tr> <td>4</td> <td>125\pm3</td> </tr> <tr> <td>5</td> <td>25\pm2</td> </tr> </tbody> </table>	Step	Temperature (°C)	1	25 \pm 2	2	-55 \pm 3	3	25 \pm 2	4	125 \pm 3	5	25 \pm 2
				Step	Temperature (°C)											
1	25 \pm 2															
2	-55 \pm 3															
3	25 \pm 2															
4	125 \pm 3															
5	25 \pm 2															
9	Terminal Strength	Tensile Strength	Termination not to be broken or loosened	As in the figure, fix the capacitor body, apply the force gradually to each lead in the radial direction of the capacitor until reaching 10N and then keep the force applied for 10 \pm 1 sec. 												
		Bending Strength	Termination not to be broken or loosened													
10	Vibration Resistance	Appearance	No defects or abnormalities	The capacitor should be firmly soldered to the supporting lead wire and vibrated at a frequency range of 10 to 55Hz, 1.5mm in total amplitude, with about a 1 minute rate of vibration change from 10Hz to 55Hz and back to 10Hz. Apply for a total of 6 hrs., 2 hrs. each in 3 mutually perpendicular directions.												
		Capacitance	Within the specified tolerance													
		D.F.	0.01 max.													

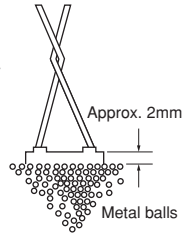

Continued on the following page.

Specifications and Test Methods

Continued from the preceding page.

No.	Item	Specifications	Test Method															
11	Solderability of Leads	Lead wire should be soldered with uniform coating on the axial direction over 3/4 of the circumferential direction.	The terminal of a capacitor is dipped into a solution of ethanol (JIS-K-8101) and rosin (JIS-K-5902) (25% rosin in weight proportion) and then into molten solder (JIS-Z-3282) for 2±0.5 sec. In both cases the depth of dipping is up to about 1.5 to 2mm from the terminal body. Temp. of solder: 245±5°C Lead Free Solder (Sn-3.0Ag-0.5Cu) 235±5°C H60A or H63A Eutectic Solder															
12	Resistance to Soldering Heat	Appearance	The lead wire is immersed in the melted solder 1.5 to 2mm from the main body at 350±10°C for 3.5±0.5 sec. The specified items are measured after 24±2 hrs. • Pretreatment Perform a heat treatment at 150+0/-10°C for 1 hr., and then let sit at room temperature for 24±2 hrs.															
		Capacitance Change		Within ±10%														
		Dielectric Strength (Between Terminals)		No defects														
13	Temperature Cycle	Appearance	The capacitor should be subjected to 5 temperature cycles. <table border="1"> <thead> <tr> <th>Step</th> <th>Temperature (°C)</th> <th>Time (min)</th> </tr> </thead> <tbody> <tr> <td>1</td> <td>-55±3</td> <td>30±3</td> </tr> <tr> <td>2</td> <td>Room Temp.</td> <td>3 max.</td> </tr> <tr> <td>3</td> <td>125±3</td> <td>30±3</td> </tr> <tr> <td>4</td> <td>Room Temp.</td> <td>3 max.</td> </tr> </tbody> </table> • Pretreatment Perform a heat treatment at 150+0/-10°C for 1 hr., and then let sit at room temperature for 24±2 hrs.	Step	Temperature (°C)	Time (min)	1	-55±3	30±3	2	Room Temp.	3 max.	3	125±3	30±3	4	Room Temp.	3 max.
		Step		Temperature (°C)	Time (min)													
		1		-55±3	30±3													
		2		Room Temp.	3 max.													
		3		125±3	30±3													
4	Room Temp.	3 max.																
Capacitance Change	Within ±7.5%																	
D.F.	0.01 max.																	
Insulation Resistance	More than 10,000MΩ or 100MΩ · μF (Whichever is smaller)																	
Dielectric Strength (Between Terminals)	No defects or abnormalities																	
14	Humidity (Steady State)	Appearance	Set the capacitor at 40±2°C and relative humidity of 90 to 95% for 500 ± ²⁴ ₀ hrs. Remove and set for 24±2 hrs. at room temperature, then measure. • Pretreatment Perform a heat treatment at 150+0/-10°C for 1 hr., and then let sit at room temperature for 24±2 hrs.															
		Capacitance Change		Within ±12.5%														
		D.F.		0.02 max.														
		Insulation Resistance		More than 1,000MΩ or 10MΩ · μF (Whichever is smaller)														
15	Humidity Load	Appearance	Apply the rated voltage at 40±2°C and relative humidity of 90 to 95% for 500 ± ²⁴ ₀ hrs. Remove and set for 24±2 hrs. at room temperature, then measure. (Charge/Discharge current ≤ 50mA) • Pretreatment Perform a heat treatment at 150+0/-10°C for 1 hr., and then let sit at room temperature for 24±2 hrs.															
		Capacitance Change		Within ±12.5%														
		D.F.		0.02 max.														
		Insulation Resistance		More than 1,000MΩ or 10MΩ · μF (Whichever is smaller)														
16	High Temperature Load	Appearance	Apply voltage in Table for 1000 ± ⁴⁸ ₀ hrs. at the maximum operating temperature. Remove and set for 24±2 hrs. at room temperature, then measure. (Charge/Discharge current ≤ 50mA) <table border="1"> <thead> <tr> <th>Rated Voltage</th> <th>Test Voltage</th> </tr> </thead> <tbody> <tr> <td>DC250V</td> <td>150% of the rated voltage</td> </tr> <tr> <td>DC450V</td> <td>130% of the rated voltage</td> </tr> <tr> <td>DC630V</td> <td>120% of the rated voltage</td> </tr> </tbody> </table> • Pretreatment Apply test voltage for 1 hr., at test temperature. Remove and set for 24±2 hrs. at room temperature.	Rated Voltage	Test Voltage	DC250V	150% of the rated voltage	DC450V	130% of the rated voltage	DC630V	120% of the rated voltage							
		Rated Voltage		Test Voltage														
		DC250V		150% of the rated voltage														
		DC450V		130% of the rated voltage														
DC630V	120% of the rated voltage																	
Capacitance Change	Within ±12.5%																	
D.F.	0.02 max.																	
Insulation Resistance	More than 1,000MΩ or 10MΩ · μF (Whichever is smaller)																	
17	Solvent Resistance	Appearance	The capacitor should be fully immersed, unagitated, in reagent at 20 to 25°C for 30±5 sec. and then removed gently. Marking on the surface of the capacitor should immediately be visually examined. Reagent : • Isopropyl alcohol															
		Marking		Legible														